



(51) International Patent Classification:

G03B 15/00 (2021.01) G03B 17/56 (2021.01)
G03B 17/00 (2021.01) G03B 29/00 (2021.01)

(71) Applicant: **FACEBOOK TECHNOLOGIES, LLC**

[US/US]; c/o Rimon Law/Steven Colby, 420 West Main Street, Suite 101B, Boise, Idaho 83702 (US).

(21) International Application Number:

PCT/US2021/038929

(72) Inventor: **COTOROS, Ingrid Anda**; 1601 Willow Road, Menlo Park, California 94025 (US).

(22) International Filing Date:

24 June 2021 (24.06.2021)

(74) Agent: **COLBY, Steven et al.**; Rimon Law, 420 West Main Street, Suite 101B, Boise, Idaho 83702 (US).

(25) Filing Language:

English

(81) Designated States (unless otherwise indicated, for every kind of national protection available): AE, AG, AL, AM, AO, AT, AU, AZ, BA, BB, BG, BH, BN, BR, BW, BY, BZ, CA, CH, CL, CN, CO, CR, CU, CZ, DE, DJ, DK, DM, DO, DZ, EC, EE, EG, ES, FI, GB, GD, GE, GH, GM, GT, HN, HR, HU, ID, IL, IN, IR, IS, IT, JO, JP, KE, KG, KH, KN, KP, KR, KW, KZ, LA, LC, LK, LR, LS, LU, LY, MA, MD, ME, MG, MK, MN, MW, MX, MY, MZ, NA, NG, NI, NO, NZ, OM, PA, PE, PG, PH, PL, PT, QA, RO, RS, RU, RW,

(26) Publication Language:

English

(30) Priority Data:

63/049,520 08 July 2020 (08.07.2020) US
17/035,554 28 September 2020 (28.09.2020) US

(54) Title: DETACHABLE CAMERA BLOCK FOR A WEARABLE DEVICE

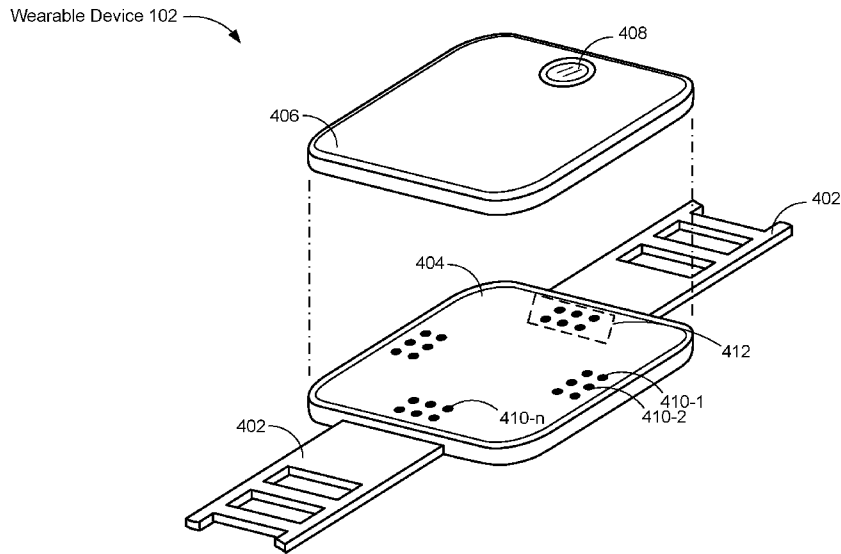

Figure 4

(57) Abstract: A wearable device (102) includes a strap (402), a base (404) connected to the strap, a display (406) detachably connected to the base, and a camera (408) embedded within the display. The display is configured to rotate around a perimeter of the base to adjust the orientation of the camera with respect to the base. Rotating the display allows the camera to capture one or more fields-of-view at different positions with respect to the base. In some embodiments, the display includes two or more cameras having distinct lenses. In some embodiments, the lenses of the two or more cameras are macro lenses, prime telephoto lenses, optical zoom lenses, or normal lenses. In some embodiments, the wearable device includes a second alternative display having one or more embedded second cameras. The second display is configured to detachably couple to the base after detaching the first display.



SA, SC, SD, SE, SG, SK, SL, ST, SV, SY, TH, TJ, TM, TN,
TR, TT, TZ, UA, UG, US, UZ, VC, VN, WS, ZA, ZM, ZW.

(84) Designated States (*unless otherwise indicated, for every kind of regional protection available*): ARIPO (BW, GH, GM, KE, LR, LS, MW, MZ, NA, RW, SD, SL, ST, SZ, TZ, UG, ZM, ZW), Eurasian (AM, AZ, BY, KG, KZ, RU, TJ, TM), European (AL, AT, BE, BG, CH, CY, CZ, DE, DK, EE, ES, FI, FR, GB, GR, HR, HU, IE, IS, IT, LT, LU, LV, MC, MK, MT, NL, NO, PL, PT, RO, RS, SE, SI, SK, SM, TR), OAPI (BF, BJ, CF, CG, CI, CM, GA, GN, GQ, GW, KM, ML, MR, NE, SN, TD, TG).

Published:

— *with international search report (Art. 21(3))*

Detachable Camera Block for a Wearable Device

CROSS-REFERENCE TO RELATED APPLICATION

[0001] This application claims priority to U.S. Provisional Patent Application No. 63/049,520, filed July 8, 2020, entitled “Detachable Camera Block for a Wearable Device”; and to U.S. non-Provisional Patent Application No. 17/035,554 filed Sept. 28, 2020, which are both incorporated herein by reference in their entirety.

TECHNICAL FIELD

[0002] This application relates generally to cameras on wearable devices, and more specifically to wearable devices with dynamically configurable cameras.

BACKGROUND

[0003] When a wearable device or a portable device includes a camera, the camera typically has a fixed orientation and fixed focal parameters. This limits the ways in which the camera can be used.

[0004] Artificial reality often provides a rich, immersive experience in which users are able to interact with virtual objects and/or environments. In this context, artificial reality may constitute a form of reality that has been altered by virtual objects for presentation to a user. Such artificial reality may include and/or represent virtual reality (VR), augmented reality (AR), mixed reality (MR), hybrid reality, or some combination and/or variation one or more of the same. Although artificial reality systems are commonly implemented for gaming and other entertainment purposes, such systems are also implemented for purposes outside of recreation. For example, governments may use them for military training simulations, doctors may use them to practice surgery, engineers may use them as visualization aids, and co-workers may use them to facilitate inter-personal interactions and collaboration from across the globe.

[0005] Head-mounted display devices (also called head-mounted displays) are gaining popularity as a means for providing visual information to a user. For example, some head-mounted display devices are used for virtual reality and augmented reality operations.

SUMMARY

[0006] When using head-mounted display devices, it may be desirable for the user to be able to observe the outside environment. For instance, while using the head-mounted display device, a user may want to look down at his or her hands in order to view a keyboard, a mouse, or a controller, or to interact with adjacent objects, such as grabbing a cup of tea, without having to remove the head-mounted display device. In such cases, separate cameras

1 or wearable devices having integrated cameras can record/track the outside environment and
2 such data can be used to aid the user and enhance the AR/VR experience.

3 **[0007]** According to an aspect of the present invention, there is provided a wearable
4 device, comprising: a strap; a base coupled to the strap; a display detachably coupled to the
5 base; and a camera embedded within the display, wherein the display is configured to rotate
6 around an axis normal to the base to adjust an orientation of the camera with respect to the
7 base.

8 **[0008]** Preferably, the display includes two or more cameras having distinct lenses.

9 **[0009]** Preferably, the lenses of the two or more cameras are selected from the group
10 consisting of: a macro lens, a prime telephoto lens, an optical zoom lens, and a normal lens.

11 **[0010]** Preferably, adjusting the orientation of the camera changes a field-of-view of
12 the camera.

13 **[0011]** Preferably, the display is a first display, and the wearable device assembly
14 further comprises a second display having one or more second cameras embedded within the
15 second display, distinct from the first display, the second display configured to detachably
16 couple to the base in place of the first display.

17 **[0012]** Preferably, the base and the display are both square shaped, the base and the
18 display are both circular in shape, or the base and the display are both rectangular in shape.

19 **[0013]** Preferably, the base and the display share a shape that has a plurality of
20 rotational symmetries around a central perpendicular axis to the display.

21 **[0014]** Preferably, the base includes one or more pads configured to
22 electromagnetically connect to one or more pads of the display.

23 **[0015]** Preferably, the display includes one or more pads configured to electrically
24 connect to one or more pads of the base.

25 **[0016]** Preferably, the base includes one or more pads configured to electrically
26 connect to one or more pads of the display.

27 **[0017]** Preferably, the one or more pads of the display are configured to magnetically
28 adhere to the one or more pads of the base using magnetic coupling between the pads of the
29 display and the pads of the base.

30 **[0018]** Preferably, the one or more pads of the display are configured to mechanically
31 latch to the one or more pads of the base.

32 **[0019]** Preferably, the display is configured to make an electrical connection between
33 the one or more pads of the display with the one or more pads of the base at any of a
34 predetermined set rotational orientations of the display with respect to the base.

1 [0020] According to a second aspect of the present invention there is provided a
2 method, comprising: at a wearable device having a strap, a base coupled to the strap, and a first
3 display detachably coupled to the base, wherein the first display has a first camera: detaching
4 the first display from the base; and attaching a second display to the base, wherein the second
5 display (i) is distinct from the first display and (ii) has a second camera.

6 [0021] Preferably, the method further comprises: rotating the second display about an
7 axis normal to the base in a first direction to capture, using the second camera, a first field-of-
8 view; and rotating the second display about the axis normal to the base in a second direction,
9 distinct from the first direction, to capture, using the second camera, a second field-of-view
10 that is distinct from the first field-of-view.

11 [0022] Preferably, the second display includes two or more cameras having distinct
12 lenses.

13 [0023] Preferably, the lenses of the two or more cameras are selected from the group
14 consisting of: a macro lens, a prime telephoto lens, an optical zoom lens, and a normal lens.

15 [0024] Preferably, the base includes one or more pads configured to electrically
16 connect to respective pads of the first display or the second display, or the base includes one
17 or more pads configured to electromagnetically connect to respective pads of the first display
18 or the second display.

19 [0025] Preferably, the base includes one or more pads and each of the first and the
20 second displays is configured to make a respective electrical connection between respective
21 pads of the respective display with the one or more pads of the base at any of a set of
22 predetermined rotational orientations of the respective display with respect to the base.

23 [0026] According to a further aspect of the present invention there is provided a system,
24 comprising: a wearable device, including: a strap; a base coupled to the strap; a display
25 detachably coupled to the base; and a camera embedded within the display, wherein the display
26 is configured to rotate around an axis normal to the base to adjust an orientation of the camera
27 with respect to the base; and an artificial reality headset in communication with the wearable
28 device.

29 [0027] The present disclosure identifies and addresses the need for additional systems
30 and methods for adjusting one or more camera angles to view an environment of a wearer. In
31 some embodiments this enhances artificial reality sensory experiences.

32 [0028] The present disclosure generally relates to systems and methods for
33 interchanging displays with various camera capabilities on wearable devices worn by users. In
34 some embodiments, a system includes a wearable device to be worn by a user of an artificial

1 reality system. The wearable device includes a strap, a base, and a display detachably coupled
2 to the base. The display includes at least one camera, which is configured to rotate around an
3 axis normal to the base (e.g., the axis is normal to the base and passes through the centroid of
4 the base) to adjust the orientation of the camera with respect to the base. The base generally
5 includes all (or most) of the electronics for the wearable device, and the base is attached to the
6 strap.

7 **[0029]** In some embodiments, the display of the wearable device includes two or more
8 cameras having distinctive lenses. Each lens can be a macro lens, a prime telephoto lens, an
9 optical zoom lens, or a normal lens. This list of camera lens types is not exhaustive; other lens
10 types may be utilized.

11 **[0030]** In some embodiments, the display of the wearable device is configured to rotate
12 around an axis normal to the base to adjust the orientation of the camera to change the field-
13 of-view of the camera.

14 **[0031]** In some embodiments, the display of the wearable device is a first display. The
15 wearable device assembly further includes a second display having one or more second
16 cameras embedded within it. The second display is also configured to detachably couple to the
17 base. Each display is capable of attaching to the base, but not both at the same time.

18 **[0032]** In some embodiments, the base and the display of the wearable device are
19 square shaped. In some embodiments, the base and the display of the wearable device are
20 circular in shape. In some embodiments, the base and the display of the wearable device are
21 rectangular in shape. In some embodiments, the base and the display of the wearable device
22 have other shapes, but both the base and the display have the same shape. In some
23 embodiments, the shared shape of the base and the display has a plurality of rotational
24 symmetries around a central perpendicular axis to the display.

25 **[0033]** In some embodiments, the base of the wearable device includes one or more
26 pads configured to electrically connect to one or more pads of the display. In some
27 embodiments, the base of the wearable device includes one or more pads configured to
28 electromagnetically connect to one or more pads of the display. The pads on the base and the
29 display comprise a conductive material (e.g., metal). The pads may be spring loaded, or may
30 be bent away from the surface in order to create strong electrical connections when the base
31 pads touch the display pads. The pads may be arranged in various array patterns, such as the
32 2 x 3 arrays shown in Figure 4. In some embodiments the pads are circular dots. In other
33 embodiments, the pads are square or rectangular. In some embodiments, all of the pads within

1 a group have the same size and shape. In some embodiments, the pads are arranged in groups,
2 and the groups have rotational symmetry around a central axis perpendicular to the display.

3 **[0034]** In some embodiments, the pads have two or more distinct sizes and/or shapes.

4 **[0035]** In some embodiments, the display of the wearable device includes one or more
5 pads configured to electrically connect to one or more pads of the base.

6 **[0036]** In some embodiments, the display of the wearable device includes one or more
7 pads configured to electromagnetically connect to one or more pads of the base.

8 **[0037]** In some embodiments, the one or more pads of the base are configured to
9 magnetically connect to one or more pads of the display.

10 **[0038]** In some embodiments, the pads of the wearable device electrically connect the
11 display to the base at 0, 45, 90, 135, and 270 degree orientations with respect to a first
12 orientation.

13 **[0039]** In some embodiments, the wearable device includes a wristband dimensioned
14 to be worn on a wrist of the user.

15 **[0040]** A wearable device may be part of an artificial reality system. The artificial
16 reality system may include one or more wearable devices and a head-mounted display (HMD).

17 **[0041]** A corresponding method utilizes a wearable device having a strap, a base
18 coupled to the strap, and a first display coupled to the base. The first display has a first camera.
19 The method includes (1) detaching the first display from the base and (2) attaching a second
20 display (having a second camera) to the base. The second display is distinct from the first
21 display. In some embodiments, the method includes (3) rotating the second display around an
22 axis normal to the base in a first direction to capture, using the second camera, a first field-of-
23 view and (4) rotating the second display around the axis in a second direction, distinct from the
24 first direction to capture, using the second camera, a second field-of-view.

25 **[0042]** Various advantages of the present application will be apparent in light of the
26 descriptions below.

27 **BRIEF DESCRIPTION OF THE DRAWINGS**

28 **[0043]** For a better understanding of the various described embodiments, reference
29 should be made to the Detailed Description below, in conjunction with the following drawings
30 in which like reference numerals refer to corresponding parts throughout the figures and
31 description.

32 **[0044]** Figure 1 is a block diagram illustrating an artificial reality system, in accordance
33 with some embodiments.

1 [0045] Figure 2 is a block diagram illustrating a wearable device in accordance with
2 some embodiments.

3 [0046] Figure 3 is a block diagram illustrating a computer system in accordance with
4 some embodiments.

5 [0047] Figure 4 is an exploded view of a wearable device with a detachable camera
6 block, in accordance with some embodiments.

7 [0048] Figure 5 is a view of a wearable device on a user's wrist, in accordance with
8 some embodiments.

9 [0049] Figures 6A – 6C illustrate display configurations of the wearable device in
10 accordance with some embodiments.

11 [0050] Figure 7 is a flow diagram of a method for interchanging displays with
12 detachable camera blocks on a wearable device in accordance with some embodiments.

13 [0051] Figure 8 illustrates an embodiment of an artificial reality device.

14 [0052] Figure 9 illustrates an embodiment of an augmented reality headset and a
15 corresponding neckband, in accordance with some embodiments.

16 [0053] Figure 10 illustrates an embodiment of a virtual reality headset, in accordance
17 with some embodiments.

18 [0054] Throughout the drawings, identical reference characters and descriptions
19 indicate similar, but not necessarily identical, elements. While the embodiments described
20 herein are susceptible to various modifications and alternative forms, specific embodiments
21 have been shown by way of example in the drawings and will be described in detail herein.
22 However, the embodiments described herein are not intended to be limited to the particular
23 forms disclosed.

24 DESCRIPTION OF EMBODIMENTS

25 [0055] Reference will now be made to embodiments, examples of which are illustrated
26 in the accompanying drawings. In the following description, numerous specific details are set
27 forth in order to provide an understanding of the various described embodiments. However, it
28 will be apparent to one of ordinary skill in the art that the various described embodiments may
29 be practiced without these specific details. In other instances, well-known methods,
30 procedures, components, circuits, and networks have not been described in detail so as not to
31 unnecessarily obscure aspects of the embodiments.

32 [0056] It will also be understood that, although the terms “first” and “second” are
33 sometimes used herein to describe various elements, these elements should not be limited by
34 these terms. These terms are used only to distinguish one element from another. For example,

1 a first display could be termed a second display, and, similarly, a second display could be
2 termed a first display, without departing from the scope of the various described embodiments.
3 The first display and the second display are both displays, but they are not the same display,
4 unless specified otherwise.

5 **[0057]** The terminology used in the description of the various described embodiments
6 herein is for the purpose of describing particular embodiments only and is not intended to be
7 limiting. As used in the description of the various described embodiments and the appended
8 claims, the singular forms “a,” “an,” and “the” are intended to include the plural forms as well,
9 unless the context clearly indicates otherwise. It will also be understood that the term “and/or”
10 as used herein refers to and encompasses any and all possible combinations of one or more of
11 the associated listed items. It will be further understood that the terms “includes,” “including,”
12 “comprises,” and/or “comprising,” when used in this specification, specify the presence of
13 stated features, steps, operations, elements, and/or components, but do not preclude the
14 presence or addition of one or more other features, steps, operations, elements, components,
15 and/or groups thereof.

16 **[0058]** As used herein, the term “if” means “when” or “upon” or “in response to
17 determining” or “in response to detecting” or “in accordance with a determination that,”
18 depending on the context. Similarly, the phrase “if it is determined” or “if [a stated condition
19 or event] is detected” means “upon determining” or “in response to determining” or “upon
20 detecting [the stated condition or event]” or “in response to detecting [the stated condition or
21 event]” or “in accordance with a determination that [a stated condition or event] is detected,”
22 depending on the context.

23 **[0059]** Figure 1 is a block diagram illustrating a system 100, in accordance with various
24 embodiments. While some example features are illustrated, various other features have not
25 been illustrated for the sake of brevity and so as not to obscure pertinent aspects of the example
26 embodiments disclosed herein. To that end, as a non-limiting example, the system 100 includes
27 one or more wearable devices 102 (e.g., the devices 102a, 102b, ..., 102n), which are used in
28 conjunction with a computer system 130 (e.g., a host system or a host computer). In some
29 embodiments, the system 100 provides the functionality of a virtual reality device with haptics
30 feedback, an augmented reality device with haptics feedback, a combination thereof, or
31 provides some other functionality. Some embodiments of the system 100 are described in
32 greater detail below with reference to Figures 8-10.

33 **[0060]** An example wearable device 102 (e.g., the wearable device 102a) includes, for
34 example, one or more processors/cores 104 (referred to henceforth as “processors”), memory

1 106, one or more cameras 110, one or more communications components 112, one or more
2 sensors 114, and/or a display 120. In some embodiments, these components are interconnected
3 by way of a communications bus 108. References to these components of the wearable device
4 102 cover embodiments in which one or more of these components (and combinations thereof)
5 are included. In some embodiments, the one or more sensors 114 are part of the one or more
6 cameras 110.

7 **[0061]** In some embodiments, a single processor 104 (e.g., the processor 104 of a first
8 wearable device 102a) executes software modules for controlling multiple wearable devices
9 102 (e.g., all of the wearable devices 102a, 102b, ..., 102n). In some embodiments, a single
10 wearable device 102 (e.g., the wearable device 102a) includes multiple processors 104, one or
11 more communications component processors (e.g., configured to control communications
12 transmitted by the communications component 112 and/or receive communications by way of
13 the communications component 112) and/or one or more sensor processors (e.g., configured to
14 control operation of the sensors 114 and/or receive output from the sensors 114).

15 **[0062]** The computer system 130 is a computing device that may execute virtual reality
16 applications and/or augmented reality applications to process input data from the sensors 145
17 on the head-mounted display 140 and the sensors 114 on the wearable device 102. The
18 computer system 130 provides output data for (i) the electronic display 144 on the head-
19 mounted display 140 and (ii) the wearable device 102. In some embodiments, the computer
20 system 130 includes one or more processors/cores 132, memory 134, one or more
21 communications components 136, and/or one or more cameras 139. In some embodiments,
22 these components are interconnected by way of a communications bus 138. References to
23 these components of the computer system 130 cover embodiments in which one or more of
24 these components (and combinations thereof) are included.

25 **[0063]** In some embodiments, the computer system 130 is a standalone device that is
26 coupled to a head-mounted display 140. For example, the computer system 130 has
27 processors/cores 132 for controlling one or more functions of the computer system 130 and the
28 head-mounted display 140 has processors/cores 141 for controlling one or more functions of
29 the head-mounted display 140. Alternatively, in some embodiments, the head-mounted display
30 140 is a component of computer system 130. For example, the processors 132 control functions
31 of the computer system 130 and the head-mounted display 140. In addition, in some
32 embodiments, the head-mounted display 140 includes one or more processors 141, which
33 communicate with the processors 132 of the computer system 130. In some embodiments,
34 communications between the computer system 130 and the head-mounted display 140 occur

1 via a wired connection between the communications bus 138 and the communications bus 146.
2 In some embodiments, the computer system 130 and the head-mounted display 140 share a
3 single communications bus. In some instances the head-mounted display 140 is separate from
4 the computer system 130 (not shown).

5 **[0064]** The computer system 130 may be any suitable computer device, such as a laptop
6 computer, a tablet device, a netbook computer, a personal digital assistant, a mobile phone, a
7 smart phone, a virtual reality device (e.g., a virtual reality (VR) device, an augmented reality
8 (AR) device, or the like), a gaming device, a computer server, or any other computing device.
9 The computer system 130 is sometimes called a host or a host system. In some embodiments,
10 the computer system 130 includes other user interface components such as a keyboard, a touch-
11 screen display, a mouse, a track-pad, and/or supplemental I/O devices to add functionality to
12 the computer system 130.

13 **[0065]** In some embodiments, the one or more cameras 139 of the computer system
14 130 are used to facilitate virtual reality and/or augmented reality. Moreover, in some
15 embodiments, the one or more cameras 139 also act as projectors to display the virtual and/or
16 augmented images. In some embodiments, the computer system includes one or more distinct
17 projectors. In some embodiments, the computer system 130 provides images captured by the
18 one or more cameras 139 to the display 144 of the head-mounted display 140, and the display
19 144 in turn displays the provided images. In some embodiments, the processors 141 of the
20 head-mounted display 140 process the provided images. In some embodiments the one or more
21 cameras 139 are part of the head-mounted display 140.

22 **[0066]** The head-mounted display 140 presents media to a user. Examples of media
23 presented by the head-mounted display 140 include images, video, audio, or some combination
24 thereof. In some embodiments, audio is presented via an external device (e.g., speakers and/or
25 headphones) that receives audio information from the head-mounted display 140, the computer
26 system 130, or both, and presents audio data based on the audio information. In some
27 embodiments, the head-mounted display 140 includes one or more processors/cores 141,
28 memory 142, and/or one or more displays 144. In some embodiments, these components are
29 interconnected by way of a communications bus 146. References to these components of the
30 head-mounted display 140 cover embodiments in which one or more of these components (and
31 combinations thereof) are included. In some embodiments the head-mounted display 140
32 includes one or more sensors 145. Alternatively, in some embodiments, the one or more
33 sensors 145 are part of the host system 130. Figures 9 and 10 illustrate additional examples
34 (e.g., an AR system 900 and a VR system 1000) of the head-mounted display 140.

1 [0067] The electronic display 144 displays images to the user in accordance with data
2 received from the computer system 130. In various embodiments, the electronic display 144
3 comprises a single electronic display or multiple electronic displays (e.g., one display for each
4 eye of a user). The displayed images may be in virtual reality, augment reality, or mixed reality.

5 [0068] The optional sensors 145 include one or more hardware devices that detect
6 spatial and motion information about the head-mounted display 140. Spatial and motion
7 information can include information about the position, orientation, velocity, rotation, and
8 acceleration of the head-mounted display 140. For example, the sensors 145 may include one
9 or more inertial measurement units (IMUs) that detect rotation of the user's head while the user
10 is wearing the head-mounted display 140. This rotation information can then be used (e.g., by
11 the computer system 130) to adjust the images displayed on the electronic display 144. In some
12 embodiments, each IMU includes one or more gyroscopes, accelerometers, and/or
13 magnetometers to collect the spatial and motion information. In some embodiments, the
14 sensors 145 include one or more cameras positioned on the head-mounted display 140.

15 [0069] The communications component 112 of the wearable device 102 includes a
16 communications component antenna for communicating with the computer system 130.
17 Moreover, the communications component 136 of the computer system include a
18 complementary communications component antenna that communicates with the
19 communications component 112 of the wearable device. The respective communication
20 components are discussed in further detail below with reference to Figures 2 and 3.

21 [0070] In some embodiments, data contained within communication signals 118 is used
22 by the wearable device 102 for selecting values for characteristics used by the cameras 110 to
23 instruct the user to adjust a camera on the display of the wearable device. For example, the
24 wearable device receives an instruction from computer system 130 to capture a video stream
25 from a wide-angle lens. The wearable device may display a graphical user interface instructing
26 the user to rotate the display to position the correct camera in the correct orientation (e.g., rotate
27 the display clockwise 90 degrees). In some embodiments, the data contained within the
28 communication signals 118 alerts the computer system 130 that the wearable device 102 is
29 ready for use.

30 [0071] Non-limiting examples of the sensors 114 and the sensors 145 include infrared
31 sensors, pyroelectric sensors, ultrasonic sensors, laser sensors, optical sensors, Doppler
32 sensors, gyro sensors, accelerometers, resonant LC sensors, capacitive sensors, heart rate
33 sensors, acoustic sensors, and inductive sensors. In some embodiments, the sensors 114 and/or
34 the sensors 145 are configured to gather data that is used to determine the hand posture of a

1 user of the wearable device and/or an impedance of the medium. Examples of sensor data
2 output by these sensors include: body temperature data, infrared range-finder data, motion data,
3 activity recognition data, silhouette detection and recognition data, gesture data, heart rate data,
4 and other wearable device data (e.g., biometric readings and output, and accelerometer data).

5 **[0072]** Figure 2 is a block diagram illustrating a representative wearable device 102 in
6 accordance with some embodiments. In some embodiments, the wearable device 102 includes
7 one or more processing units 104 (e.g., CPUs, microprocessors, and the like), one or more
8 communication components 112, memory 106, one or more cameras 110, and one or more
9 communication buses 108 for interconnecting these components (sometimes called a chipset).
10 In some embodiments, the wearable device 102 includes one or more sensors 114 as described
11 above with reference to Figure 1. In some embodiments (not shown), the wearable device 102
12 includes one or more output devices such as one or more indicator lights, a sound card, a
13 speaker, or a small display for displaying textual information and error codes.

14 **[0073]** The communication components 112 enable communication between the
15 wearable device 102 and one or more communication networks. In some embodiments, the
16 communication components 112 include hardware capable of data communications using any
17 of a variety of wireless protocols (e.g., IEEE 802.15.4, Wi-Fi, ZigBee, 6LoWPAN, Thread, Z-
18 Wave, Bluetooth Smart, ISA100.11a, WirelessHART, or MiWi) wired protocols (e.g., Ethernet
19 or HomePlug), and/or any other suitable communication protocol.

20 **[0074]** The memory 106 includes high-speed random access memory, such as DRAM,
21 SRAM, DDR SRAM, or other random access solid state memory devices. In some
22 embodiments, the memory includes non-volatile memory, such as one or more magnetic disk
23 storage devices, one or more optical disk storage devices, one or more flash memory devices,
24 or one or more other non-volatile solid state storage devices. The memory 106, or alternatively
25 the non-volatile memory within memory 106, includes a non-transitory computer-readable
26 storage medium. In some embodiments, the memory 106, or the non-transitory computer-
27 readable storage medium of the memory 106, stores the following programs, modules, and data
28 structures, or a subset or superset thereof:

- 29 • operating logic 216, including procedures for handling various basic system services
30 and for performing hardware dependent tasks;
- 31 • a communication module 218, which communicates with remote devices (e.g., a
32 computer system 130 or other wearable devices) in conjunction with communication
33 components 112;

- 1 • a sensor module 220, which obtains and processes sensor data (e.g., in conjunction
2 with the sensors 114 and/or the cameras 110). The sensor module can determine the
3 orientation of the wearable device 102 or determine the environmental conditions of
4 the user of the wearable device;
- 5 • a connection detection module 222, which identifies which of the multiple
6 interchangeable displays is attached to the base of the wearable device. In some
7 embodiments, the connection detection module 222 also includes an orientation
8 module 224, which identifies the orientation of the attached display with respect to the
9 base; and
- 10 • a database 226, which stores:
 - 11 ○ sensor information 228 received, detected, and/or transmitted by one or more
12 sensors 114, one or more remote sensors, and/or cameras;
 - 13 ○ device settings 230 for the wearable device 102 and/or one or more remote
14 devices (e.g., selected preferred orientations for the cameras); and
 - 15 ○ communication protocol information 232 for one or more protocols (e.g.,
16 custom or standard wireless protocols, such as ZigBee or Z-Wave, and/or
17 custom or standard wired protocols, such as Ethernet).

18 **[0075]** In some embodiments (not shown), the wearable device 102 includes a location
19 detection device, such as a GNSS (e.g., GPS or GLONASS) or other geo-location receiver, for
20 determining the location of the wearable device 102. In some embodiments, the wearable
21 device 102 includes a location detection module (e.g., a GPS, Wi-Fi, magnetic, or hybrid
22 positioning module) for determining the location of the wearable device 102 (e.g., using the
23 location detection device) and providing this location information to the host system 130.

24 **[0076]** In some embodiments (not shown), the wearable device 102 includes a unique
25 identifier stored in the database 226. In some embodiments, the wearable device 102 sends the
26 unique identifier to the host system 130 to identify itself to the host system 130. This is
27 particularly useful when multiple wearable devices are being used concurrently.

28 **[0077]** In some embodiments, the wearable device 102 includes one or more inertial
29 measurement units (IMU) for detecting motion and/or a change in orientation of the wearable
30 device 102. In some embodiments, the detected motion and/or orientation of the wearable
31 device 102 (e.g., the motion/change in orientation corresponding to movement of the user's
32 hand) is used to manipulate an interface (or content within the interface) displayed by the head-
33 mounted display 140. In some embodiments, the IMU includes one or more gyroscopes,
34 accelerometers, and/or magnetometers to collect IMU data. In some embodiments, the IMU

1 measures motion and/or a change in orientation for multiple axes (e.g., three axes or six axes).
2 In such instances, the IMU may include one or more instruments for each of the multiple axes.
3 The one or more IMUs may be part of the one or more sensors 114.

4 **[0078]** Each of the above-identified elements (e.g., modules stored in memory 106 of
5 the wearable device 102) can be stored in one or more of the previously mentioned memory
6 devices, and corresponds to a set of instructions for performing the functions described above.
7 The above identified modules or programs (e.g., sets of instructions) need not be implemented
8 as separate software programs, procedures, or modules, and thus various subsets of these
9 modules can be combined or otherwise rearranged in various embodiments. In some
10 embodiments, the memory 106 stores a subset of the modules and data structures identified
11 above. In some embodiments, the memory 106 stores additional modules and data structures
12 not described above.

13 **[0079]** Figure 3 is a block diagram illustrating a representative computer system 130 in
14 accordance with some embodiments. In some embodiments, the computer system 130 includes
15 one or more processing units/cores 132 (e.g., CPUs, GPUs, microprocessors, and the like), one
16 or more communication components 136, memory 134, one or more cameras 139, and one or
17 more communication buses 138 for interconnecting these components (sometimes called a
18 chipset). In some embodiments, the computer system 130 includes a head-mounted display
19 interface 305 for connecting the computer system 130 with the head-mounted display 140. As
20 discussed above in Figure 1, in some embodiments, the computer system 130 and the head-
21 mounted display 140 are together in a single device, whereas in other embodiments the
22 computer system 130 and the head-mounted display 140 are separate from one another.

23 **[0080]** Although not shown, in some embodiments, the computer system (and/or the
24 head-mounted display 140) includes one or more sensors 145 (as discussed above with
25 reference to Figure 1).

26 **[0081]** The communication components 136 enable communication between the
27 computer system 130 and one or more communication networks. In some embodiments, the
28 communication components 136 include hardware capable of data communications using any
29 of a variety of custom or standard wireless protocols (e.g., IEEE 802.15.4, Wi-Fi, ZigBee,
30 6LoWPAN, Thread, Z-Wave, Bluetooth Smart, ISA100.11a, WirelessHART, or MiWi)
31 custom or standard wired protocols (e.g., Ethernet or HomePlug), and/or any other suitable
32 communication protocol.

33 **[0082]** The memory 134 includes high-speed random access memory, such as DRAM,
34 SRAM, DDR SRAM, or other random access solid state memory devices. In some

1 embodiments, the memory includes non-volatile memory, such as one or more magnetic disk
2 storage devices, one or more optical disk storage devices, one or more flash memory devices,
3 or one or more other non-volatile solid state storage devices. The memory 134, or alternatively
4 the non-volatile memory within memory 134, includes a non-transitory computer-readable
5 storage medium. In some embodiments, the memory 134, or the non-transitory computer-
6 readable storage medium of the memory 134, stores the following programs, modules, and data
7 structures, or a subset or superset thereof:

- 8 • operating logic 316, including procedures for handling various basic system services
9 and for performing hardware dependent tasks;
- 10 • a communication module 318, which communicates with remote devices (e.g., the
11 wearable devices 102a, ..., 102-n, or a remote server (not shown)) in conjunction with
12 communication components 136;
- 13 • a virtual-reality generation module 320, which is used for generating virtual-reality
14 images and sending corresponding video and audio data to the HMD 140. In some
15 embodiments, the virtual-reality generation module 320 is an augmented-reality
16 generation module 320 (or the memory 134 includes a distinct augmented-reality
17 generation module), which is used for generating augmented-reality images and
18 projecting those images in conjunction with the cameras 139 and the HMD 140);
- 19 • an instruction generation module 322, which is used for generating an instruction that,
20 when sent to the wearable device 102 (e.g., using the communications component
21 136), causes the wearable device 102 to instruct the user to adjust a display
22 orientation (e.g., rotate the display to use a different camera) and/or interchange the
23 entire display;
- 24 • a display module 324, which displays virtual-reality images and/or augmented-reality
25 images in conjunction with the head-mounted display 140 and/or the cameras 139;
- 26 • a database 326, which stores:
 - 27 ○ display information 328, including virtual-reality images and/or augmented-
28 reality images (e.g., visual data);
 - 29 ○ haptics information 330, corresponding to the stored virtual-reality images
30 and/or augmented-reality images;
 - 31 ○ communication protocol information 332 for one or more protocols (e.g.,
32 custom or standard wireless protocols, such as ZigBee or Z-Wave, and/or
33 custom or standard wired protocols, such as Ethernet); and
 - 34 ○ mapping data 334, including geographic maps.

1 [0083] In the example shown in Figure 3, the computer system 130 further includes
2 virtual-reality (and/or augmented-reality) applications 336. In some embodiments, the virtual-
3 reality applications 336 are implemented as software modules that are stored on the storage
4 device and executed by the processor. Each virtual-reality application 336 is a group of
5 instructions that, when executed by a processor, generates virtual reality content for
6 presentation to the user. A virtual-reality application 336 may generate virtual-reality content
7 in response to inputs received from the user via movement of the head-mounted display 140 or
8 the wearable device 102. Examples of virtual-reality applications 336 include gaming
9 applications, conferencing applications, and video playback applications.

10 [0084] The virtual-reality generation module 320 is a software module that allows
11 virtual-reality applications 336 to operate in conjunction with the head-mounted display 140
12 and the wearable device 102. The virtual-reality generation module 320 may receive
13 information from the sensors 145 on the head-mounted display 140 and may, in turn provide
14 the information to a virtual-reality application 336. Based on the received information, the
15 virtual-reality generation module 320 determines media content to provide to the head-mounted
16 display 140 for presentation to the user via the electronic display 144. For example, if the
17 virtual-reality generation module 320 receives information from the sensors 145 on the head-
18 mounted display 140 indicating that the user has looked to the left, the virtual-reality generation
19 module 320 generates content for the head-mounted display 140 that mirrors the user's
20 movement in a virtual environment.

21 [0085] Similarly, in some embodiments, the virtual-reality generation module 320
22 receives information from the sensors 114 on the wearable device 102 and provides the
23 information to a virtual-reality application 336. The application 336 can use the information
24 to perform an action within the virtual world of the application 336. For example, if the virtual-
25 reality generation module 320 receives information from the sensors 114 and/or cameras 110,
26 139 that the user has raised his hand, a simulated hand (e.g., the user's avatar) in the virtual-
27 reality application 336 lifts to a corresponding height. As noted above, the information
28 received by the virtual-reality generation module 320 can also include information from the
29 head-mounted display 140. For example, the cameras 139 on the head-mounted display 140
30 may capture movements of the user (e.g., movement of the user's arm), and the application 336
31 can use this additional information to perform the action within the virtual world of the
32 application 336.

33 [0086] To further illustrate with an augmented reality example, if the augmented-
34 reality generation module 320 receives information from the sensors 114, the cameras 110,

1 and/or the cameras 139, the content in the head-mounted display updates accordingly. When
2 the information indicates that the user has rotated his forearm while a user interface (e.g., a
3 keypad) is displayed on the user's forearm, the augmented-reality generation module 320
4 generates content for the head-mounted display 140 that mirrors the user's movement in the
5 augmented environment (e.g., the user interface rotates in accordance with the rotation of the
6 user's forearm).

7 **[0087]** Each of the above identified elements (e.g., the modules stored in the memory
8 134 of the computer system 130) can be stored in one or more of the previously mentioned
9 memory devices, and corresponds to a set of instructions for performing the function(s)
10 described above. The above identified modules or programs (e.g., sets of instructions) need
11 not be implemented as separate software programs, procedures, or modules, and thus various
12 subsets of these modules can be combined or otherwise rearranged in various embodiments.
13 In some embodiments, the memory 134 stores a subset of the modules and data structures
14 identified above.

15 **[0088]** Figure 4 is a view of a wearable device 102 with a detachable camera block in
16 accordance with some embodiments. The wearable device 102 includes a strap 402, a base
17 404 coupled to the strap 402, and a display 406 having a camera 408. The display 406 is shown
18 detached from the base 404, but it is typically coupled to the base 404. In some embodiments,
19 the display 406 is an electronic display configured to display a graphical user interface. The
20 base 404 includes one or more pads 410-1 to 410-n distributed in sections (e.g., a first section
21 412) about a surface of the base 404. The wearable device 102 may include multiple sections
22 412, each having one or more pads 410. The pads 410 may be made of a conductive metallic
23 element to electrically, electromagnetically, and/or magnetically connect to one or more
24 corresponding pads (not shown) on the side of the display 406 configured to connect to the
25 base 404 (e.g., pads on an opposite side of the display from the side having the one or more
26 embedded cameras). Some embodiments include one or more mechanical locking mechanisms
27 (not shown) to affix the display 406 to the base or the strap to provide an additional layer of
28 connection between the display 406 and the base 404.

29 **[0089]** In some embodiments, the base 404 includes multiple sections of pads, such as
30 the first section 412. The illustrated embodiment includes four sections, each with six pads
31 410 arranged in a 2 x 3 array. In some embodiments, the underside of the display 406 includes
32 a single section 412 of pads 410, and the orientation of the display 406 with respect to the base
33 404 determines which section of pads 410 from the base 404 connects to the pads on the
34 display. In the illustrated embodiment, there are four possible orientations of the display 406

1 with respect to the base 404 (i.e., at 0°, 90°, 180°, and 270°). In the depicted embodiment, only
2 the pads 410 from a single section are used at any given time, but other embodiments have one
3 or more pads 410 that are shared and/or pads 410 that are not part of a section. For example,
4 some embodiments include one or more central pads 410 that connect the base 404 to the
5 display 406 in all possible orientations.

6 **[0090]** Having a detachable display 406 provides some flexibility for the electrical
7 components of the wearable device 102. In some embodiments, substantially all of the
8 electronic components are included in the base 404, and the detachable display 406 is just a
9 “display” with one or more cameras 408. In other embodiments, some of the electrical
10 components are included in the display 406. For example, the electrical components in the
11 display 406 may include one or more image buffers for the cameras 408 or image processing
12 circuitry.

13 **[0091]** Rotation of the display 406 with respect to the base 404 refers to rotation about
14 an axis normal to both the base 404 and the display 406 (e.g., an axis normal to the base 404
15 extending through the centroid of the base 404, which would generally extend through the
16 centroid of the display 406 as well).

17 **[0092]** In some embodiments, detaching the display 406 from the base 404 is necessary
18 in order to rotate the display 406 (e.g., detach, rotate, attach). In other embodiments, the display
19 406 can be rotated with respect to the base 404 without detachment (e.g., a wearable device
20 102 with a single display 406 that can be rotated to a plurality of distinct orientations). In some
21 embodiments, there are a finite number of distinct possible orientations, and a magnetic or
22 mechanical locking mechanism to hold the display 406 at a selected orientation unless
23 sufficient user force is applied. Some embodiments provide for a continuous range of rotational
24 orientations (e.g., using annular or partially annular pads 410 on either the base 404 or the
25 display 406). Some embodiments provide for both rotation without detachment as well as
26 rotation with detachment. When detached, the user can also substitute an alternative display
27 406 (e.g., with different cameras 408).

28 **[0093]** Figure 5 is a view of a wearable device 102 affixed to a user in accordance with
29 some embodiments. The wearable device 102 is shown with respect to a user’s arm 506. In
30 some embodiments, the wearable device 102 includes three cameras 408, 510, and 512, each
31 with a distinct lens. In some embodiments, the camera 408 is activated to provide a field-of-
32 view 514. In some embodiments, the camera at a 12 o’clock position is the only camera that
33 is able to be activated. For example, if the user wants to select the camera 512, the display 406
34 must be rotated from the 9 o’clock position to the 12 o’clock position by either a clockwise or

1 counterclockwise rotation. In some embodiments, the display can be rotated while attached to
2 the base 404. In other embodiments, the display 406 must be detached (as shown in Figure 4)
3 in order to rotate the display.

4 **[0094]** The wearable device 102 may include a fastener that facilitates securing the
5 strap 402 to the wrist of the user. For example, the fastener may interface with a receptacle
6 formed integrally into the strap 402. In this example, when the strap 402 encompasses the wrist
7 of the user and the fastener is secured to the receptacle, the combination of the fastener and the
8 receptacle effectively hold the strap 402 in place on the wrist of the user. Examples of such
9 fasteners include, without limitation, members, pegs, pins, clamps, clips, latches, snaps,
10 zippers, rivets, hook and loop combinations, combinations or variations of one or more of the
11 same, and/or other suitable fasteners.

12 **[0095]** In some examples, a user may don multiple wearable devices that work in
13 conjunction with one another. For example, the user may wear one wearable on his or her left
14 wrist and another wearable on his or her right wrist. In this example, the wearable on the user's
15 left wrist may be used to capture images/video footage of the user's environment (e.g., via a
16 wide-angle lens) while the wearable device on the user's right wrist may be used to capture
17 images/video footage of the user (e.g., via a selfie camera).

18 **[0096]** Figures 6A-6C are views of a wearable device with a detachable camera block
19 in accordance with some embodiments. The wearable device 102-2 as shown in Figures 6A-
20 6C may have round or circular displays 406. Wearable devices 102 may include two or more
21 distinct cameras, each camera having a lens with a distinct capability. For example, the first
22 camera lens 608-1 on the wearable device 102-2 may be a prime telephoto lens, the second
23 camera lens 608-2 may be a normal lens, and the third camera lens 608-3 may be an optical
24 zoom lens or a fisheye lens. To select a camera for use, the display is rotated to adjust the
25 position of the desired camera to the 12 o'clock position, with respect to the base of the
26 wearable device 102. As shown in Figure 6A, the second camera lens 608-2 is selected and in
27 position for use by the user. As shown in Figure 6B, the first camera lens 608-1 is selected and
28 in position for use by the user. As shown in Figure 6C, the third camera lens 608-3 is selected
29 and in position for use by the user.

30 **[0097]** In some embodiments, each of the first camera lens 608-1, the second camera
31 lens 608-2, and the third camera lens 608-3 is a macro lens, a prime telephoto lens, an optical
32 zoom lens, or a normal lens.

33 **[0098]** In some embodiments, one or more of the cameras may be mounted on an outer
34 edge of the display 406 (not shown). In such a configuration, the display may be rotated to

1 select a camera for use. In some embodiments, the wearable device has an axial-symmetric
2 design to allow maximum freedom in orientation positions. In some embodiments, more than
3 one camera may be activated concurrently. In Figures 6A – 6C, the 12 o'clock position is
4 designated as the location for the active camera/lens. Other embodiments designate a different
5 location as the active location. In some embodiments, the base includes an active “region”
6 rather than a single active location, and whichever camera is in the active region becomes the
7 active camera. In some embodiments, the active camera is selected by software rather than by
8 hardware movement. Some embodiments use alternative means to electrically connect the
9 display to the base (other than dot-like pads). Some embodiments use alternative techniques
10 to electromagnetically connect the display to the base. For example, some embodiments use
11 connecting arcs (e.g., metal arcs curving partially around a central point of the base or the
12 display), which enable connection over a broader range of angles.

13 **[0099]** Figure 7 is a flow diagram of a method 700 of adjusting camera blocks for a
14 wearable device in accordance with some embodiments. The steps of the method 700 may be
15 performed by a wearable device 102. Figure 7 corresponds to instructions stored in computer
16 memory or a computer readable storage medium (e.g., the memory 106 of the wearable device
17 102). For example, the operations of method 700 are performed, at least in part, by a
18 communication module 218, a connection detection module 222, and/or virtual-reality
19 generation module 320.

20 **[00100]** The method 700 includes providing (702) a wearable device that has a strap, a
21 base coupled to the strap, and a first display coupled to the base. The first display has a first
22 camera. In some embodiments, the base includes (704) one or more pads configured to
23 electrically connect to one or more pads of the display. In some embodiments, the display
24 includes (706) one or more pads configured to electrically connect to one or more pads of the
25 base. In some embodiments, the one or more pads of the base are (708) further configured to
26 magnetically adhere to one or more pads of the display based on magnetic coupling between
27 the pads of the display and the pads of the base (see Figure 4). For example, the display may
28 have one or more magnetic pads that are configured to attach to one or more magnetic pads on
29 the base using an electromagnetic connection. Additionally and/or alternatively, the magnetic
30 pads may be permanent magnets. In some embodiments, the one or more pads are configured
31 to be connected to one or more pads of the base by optical data transfer. In some embodiments,
32 the base includes one or more pads configured to electromagnetically connect to one or more
33 pads of the display. In some embodiments, the one or more pads of the base are configured to
34 mechanically adhere to one or more pads of the display based on mechanical coupling between

1 the pads of the display and the pads of the base. In some embodiments, the one or more pads
2 of the base are configured to electromagnetically adhere to one or more pads of the display
3 based on mechanical coupling between the pads of the display and the pads of the base.

4 **[00101]** In some embodiments, the method includes lifting the first display to detach it
5 from the base. The method includes detaching (710) the first display from the base and
6 attaching (712) a second display to the base. The second display is distinct from the first
7 display and has a second camera. For example, a user wants to use a wide-angle lens to capture
8 the environment. However, the first display does not have a camera with a wide-angle lens.
9 The user can detach the first display in order to attach a second display having a camera with
10 the desired wide-angle lens.

11 **[00102]** In some embodiments, the second display includes (714) two or more cameras
12 having distinct lenses. In some embodiments, each of the lenses of the first and second cameras
13 is (716) one of: a macro lens, a prime telephoto lens, an optical zoom lens, or a normal lens.

14 **[00103]** In some embodiments, the first and second displays are (718) both configured
15 to make electrical connection between the one or more pads of the respective display with the
16 one or more pads of the base at any of a set of predetermined rotational orientations of the
17 display with respect to the base. In some embodiments, the one or more pads electrically,
18 electromagnetically, and/or magnetically adhere (720) the display to the base at 0, 45, 90, 135,
19 and 270 degree orientations with respect to a first orientation. In some embodiments, the one
20 or more pads electrically, electromagnetically, and/or magnetically adhere the display to the
21 base at any degree orientation between 0 and 360 degree orientations with respect to the base.
22 For example, a user can select a specific orientation of the display to allow a camera within the
23 display to sit at a specific orientation (see Figure 5). The magnetic connection is strong enough
24 to hold the base and the display together, but the magnetic force is able to be overcome by a
25 user to either (1) remove and replace the display or (2) rotate the display around an axis normal
26 to the base. In some embodiments, a secondary mechanical mechanism is locked in place and
27 thereby holds the base and the display together. In some embodiments, the lock is overcome
28 by a user to either (1) remove and replace the display or (2) rotate the display around an axis
29 normal to the base.

30 **[00104]** In some embodiments, the method includes rotating (722) the second display
31 around an axis normal to the base in a first direction to capture, using the second camera, a first
32 field-of-view. In some embodiments, one of the two or more cameras of the second display is
33 used to capture the first field-of-view.

1 [00105] In some embodiments, the method includes rotating (724) the second display
2 around the axis in a second direction, distinct from the first direction, to capture, using the
3 second camera, a second field-of-view. In some embodiments, the method includes rotating
4 the second display around the axis in either the first direction or the second direction to capture,
5 using at least one of the two or more cameras of the second display, a third field-of-view.

6 [00106] For example, a user has a first display having a first camera on a wearable device
7 worn on the wrist. The user uses the first camera to take a picture of herself (e.g., a selfie) and
8 subsequently would like to take a picture of the landscape in front of her. The user removes
9 the first display and attaches a second display having a second camera with a wide-angle lens
10 capability. The user is then able to use the second camera lens to take a picture of the landscape.
11 Additionally, the user is able to rotate the second display to select a zoom lens to take a third
12 picture that is zoomed into a specific target within the landscape. In some embodiments, the
13 wearable device is able to be worn and used distinct from a virtual-reality and/or artificial
14 reality system. For example, a user may wear the wearable device 102 to connect with a virtual-
15 reality system (e.g., Oculus Rift), to provide visual and environmental feedback for use in the
16 virtual-reality system. Additionally, the user may continue wearing wearable device 102 as a
17 smart-watch, distinct from the virtual-reality system. The wearable device may be capable of
18 pairing to another electronic device (e.g., a user's cell phone).

19 [00107] Figures 8-10 provide additional examples of the devices used in the system 100.
20 The AR system 800 in Figure 8 generally represents a wearable device dimensioned to fit about
21 a body part (e.g., a head) of a user. The AR system 800 may include the functionality of the
22 wearable device 102, and may include additional functions. As shown, the AR system 800
23 includes a frame 802 (e.g., band) and a camera assembly 804 that is coupled to the frame 802
24 and configured to gather information about a local environment by observing the local
25 environment. The AR system 800 may also include one or more transducers. In one example,
26 the AR system 800 includes output transducers 808(A) and 808(B) and input transducers 810.
27 The output transducers 808(A) and 808(B) may provide audio feedback, haptic feedback,
28 and/or content to a user, and the input audio transducers may capture audio (or other
29 signals/waves) in a user's environment. The transducers of the AR system 800 may be
30 configured to generate waves for creating haptic stimulations.

31 [00108] The AR system 800 does not include a near-eye display (NED) positioned in
32 front of a user's eyes. AR systems without NEDs may take a variety of forms, such as head
33 bands, hats, hair bands, belts, watches, wrist bands, ankle bands, rings, neckbands, necklaces,
34 chest bands, eyewear frames, and/or any other suitable type or form of apparatus. While the

1 AR system 800 may not include a NED, the AR system 800 may include other types of screens
2 or visual feedback devices (e.g., a display screen integrated into a side of the frame 802).

3 **[00109]** The embodiments discussed in this disclosure may also be implemented in AR
4 systems that include one or more NEDs. For example, as shown in Figure 9, the AR system
5 900 may include an eyewear device 902 with a frame 910 configured to hold a right display
6 device 915(A) and a left display device 915(B) in front of a user's eyes. Display devices
7 915(A) and 915(B) may act together or independently to present an image or series of images
8 to a user. While the AR system 900 includes two displays, embodiments of this disclosure may
9 be implemented in AR systems with a single NED or more than two NEDs.

10 **[00110]** In some embodiments, the AR system 900 includes one or more sensors, such
11 as the sensor 940 and the sensor 950. The sensors 940 and 950 may generate measurement
12 signals in response to motion of the AR system 900 and may be located on substantially any
13 portion of the frame 910. The sensors 940 and 950 may include a position sensor, an inertial
14 measurement unit (IMU), a depth camera assembly, or any combination thereof. The AR
15 system 900 may or may not include the sensors 940 and 950 or may include more sensors. In
16 embodiments in which the sensors 940 and 950 include an IMU, the IMU may generate
17 calibration data based on measurement signals from the sensors 940 and 950. Examples of the
18 sensors 940 and 950 include, without limitation, accelerometers, gyroscopes, magnetometers,
19 other suitable types of sensors that detect motion, sensors used for error correction of the IMU,
20 or some combination thereof. Sensors are also discussed above with reference to Figure 1 (e.g.,
21 sensors 145 of the head-mounted display 140).

22 **[00111]** The AR system 900 may also include a microphone array with a plurality of
23 acoustic sensors 920(A)-920(J), referred to collectively as acoustic sensors 920. The acoustic
24 sensors 920 may be transducers that detect air pressure variations induced by sound waves.
25 Each acoustic sensor 920 may be configured to detect sound and convert the detected sound
26 into an electronic format (e.g., an analog or digital format). The microphone array in Figure
27 14 may include, for example, ten acoustic sensors: 920(A) and 920(B), which may be designed
28 to be placed inside a corresponding ear of the user, acoustic sensors 920(C), 920(D), 920(E),
29 920(F), 920(G), and 920(H), which may be positioned at various locations on the frame 910,
30 and/or acoustic sensors 920(I) and 920(J), which may be positioned on a corresponding
31 neckband 905. In some embodiments, the neckband 905 is an example of the computer system
32 130.

33 **[00112]** The configuration of acoustic sensors 920 of the microphone array may vary.
34 While the AR system 900 is shown in Figure 9 as having ten acoustic sensors 920, the number

1 of acoustic sensors 920 may be greater or less than ten. In some embodiments, using more
2 acoustic sensors 920 may increase the amount of audio information collected and/or the
3 sensitivity and accuracy of the audio information. In contrast, using a lower number of acoustic
4 sensors 920 may decrease the computing power required by a controller 925 to process the
5 collected audio information. In addition, the position of each acoustic sensor 920 of the
6 microphone array may vary. For example, the position of an acoustic sensor 920 may include
7 a defined position on the user, a defined coordinate on the frame 910, an orientation associated
8 with each acoustic sensor, or some combination thereof.

9 **[00113]** Acoustic sensors 920(A) and 920(B) may be positioned on different parts of the
10 user's ear, such as behind the pinna or within the auricle or fossa. In some embodiments, there
11 are additional acoustic sensors on or surrounding the ear in addition to acoustic sensors 920
12 inside the ear canal. Having an acoustic sensor positioned next to an ear canal of a user may
13 enable the microphone array to collect information on how sounds arrive at the ear canal. By
14 positioning at least two of acoustic sensors 920 on either side of a user's head (e.g., as binaural
15 microphones), the AR device 900 can simulate binaural hearing and capture a 3D stereo sound
16 field around about a user's head. In some embodiments, the acoustic sensors 920(A) and
17 920(B) are connected to the AR system 900 via a wired connection, and in other embodiments,
18 the acoustic sensors 920(A) and 920(B) are connected to the AR system 900 via a wireless
19 connection (e.g., a Bluetooth connection). In still other embodiments, the acoustic sensors
20 920(A) and 920(B) are not used at all in conjunction with the AR system 900.

21 **[00114]** The acoustic sensors 920 on the frame 910 may be positioned along the length
22 of the temples, across the bridge, above or below the display devices 915(A) and 915(B), or
23 some combination thereof. The acoustic sensors 920 may be oriented such that the microphone
24 array is able to detect sounds in a wide range of directions surrounding the user wearing the
25 AR system 900. In some embodiments, an optimization process may be performed during
26 manufacturing of the AR system 900 to determine relative positioning of each acoustic sensor
27 920 in the microphone array.

28 **[00115]** The AR system 900 may further include or be connected to an external device
29 (e.g., a paired device), such as a neckband 905. As shown, the neckband 905 may be coupled
30 to the eyewear device 902 via one or more connectors 930. The connectors 930 may be wired
31 or wireless connectors and may include electrical and/or non-electrical (e.g., structural)
32 components. In some cases, the eyewear device 902 and the neckband 905 operate
33 independently without any wired or wireless connection between them. While Figure 9
34 illustrates the components of the eyewear device 902 and the neckband 905 in example

1 locations on the eyewear device 902 and the neckband 905, the components may be located
2 elsewhere and/or distributed differently on the eyewear device 902 and/or the neckband 905.
3 In some embodiments, the components of the eyewear device 902 and the neckband 905 may
4 be located on one or more additional peripheral devices paired with the eyewear device 902,
5 the neckband 905, or some combination thereof. Furthermore, the neckband 905 generally
6 represents any type or form of paired device. Thus, the following discussion of neckband 905
7 may also apply to various other paired devices, such as smart watches, smart phones, wrist
8 bands, other wearable devices, hand-held controllers, tablet computers, or laptop computers.

9 **[00116]** Pairing external devices, such as a neckband 905, with AR eyewear devices may
10 enable the eyewear devices to achieve the form factor of a pair of glasses while still providing
11 sufficient battery and computation power for expanded capabilities. Some or all of the battery
12 power, computational resources, and/or additional features of the AR system 900 may be
13 provided by a paired device or shared between a paired device and an eyewear device, thus
14 reducing the weight, heat profile, and form factor of the eyewear device overall while still
15 retaining desired functionality. For example, the neckband 905 may allow components that
16 would otherwise be included on an eyewear device to be included in the neckband 905, since
17 users may tolerate a heavier weight load on their shoulders than they would tolerate on their
18 heads. The neckband 905 may also have a larger surface area over which to diffuse and
19 disperse heat to the ambient environment. Thus, the neckband 905 may allow for greater
20 battery and computation capacity than might otherwise have been possible on a stand-alone
21 eyewear device. Since weight carried in the neckband 905 may be less invasive to a user than
22 weight carried in the eyewear device 902, a user may tolerate wearing a lighter eyewear device
23 and carrying or wearing the paired device for greater lengths of time than the user would
24 tolerate wearing a heavy standalone eyewear device, thereby enabling an artificial reality
25 environment to be incorporated more fully into a user's day-to-day activities.

26 **[00117]** The neckband 905 may be communicatively coupled with the eyewear device
27 902 and/or to other devices. The other devices may provide certain functions (e.g., tracking,
28 localizing, depth mapping, processing, or storage) to the AR system 900. In the embodiment
29 of Figure 9, the neckband 905 may include two acoustic sensors (e.g., 920(I) and 920(J)) that
30 are part of the microphone array (or potentially form their own microphone subarray). The
31 neckband 905 may also include a controller 925 and a power source 935.

32 **[00118]** The acoustic sensors 920(I) and 920(J) of the neckband 905 may be configured
33 to detect sound and convert the detected sound into an electronic format (analog or digital). In
34 the embodiment of Figure 9, the acoustic sensors 920(I) and 920(J) may be positioned on the

1 neckband 905, thereby increasing the distance between neckband acoustic sensors 920(I) and
2 920(J) and other acoustic sensors 920 positioned on the eyewear device 902. In some cases,
3 increasing the distance between the acoustic sensors 920 of the microphone array improves the
4 accuracy of beamforming performed via the microphone array. For example, if a sound is
5 detected by the acoustic sensors 920(C) and 920(D) and the distance between the acoustic
6 sensors 920(C) and 920(D) is greater than the distance between the acoustic sensors 920(D)
7 and 920(E), the determined source location of the detected sound may be more accurate than
8 if the sound had been detected by acoustic sensors 920(D) and 920(E).

9 **[00119]** The controller 925 of the neckband 905 may process information generated by
10 the sensors on the neckband 905 and/or the AR system 900. For example, the controller 925
11 may process information from the microphone array that describes sounds detected by the
12 microphone array. For each detected sound, the controller 925 may perform a direction of
13 arrival (DOA) estimation to estimate a direction from which the detected sound arrived at the
14 microphone array. As the microphone array detects sounds, the controller 925 may populate
15 an audio data set with the information. In embodiments in which the AR system 900 includes
16 an IMU, the controller 925 may compute all inertial and spatial calculations from the IMU
17 located on the eyewear device 902. The connector 930 may convey information between the
18 AR system 900 and the neckband 905 and between the AR system 900 and the controller 925.
19 The information may be in the form of optical data, electrical data, wireless data, or any other
20 transmittable data form. Moving the processing of information generated by the AR system
21 900 to the neckband 905 may reduce weight and heat in eyewear device 902, making it more
22 comfortable to a user.

23 **[00120]** The power source 935 in the neckband 905 may provide power to the eyewear
24 device 902 and/or to the neckband 905. The power source 935 may include, without limitation,
25 lithium-ion batteries, lithium-polymer batteries, primary lithium batteries, alkaline batteries, or
26 any other form of power storage. In some cases, the power source 935 is a wired power source.
27 Including the power source 935 on the neckband 905 instead of on the eyewear device 902
28 better distributes the weight and heat generated by the power source 935.

29 **[00121]** As noted, some artificial reality systems may, instead of blending an artificial
30 reality with actual reality, substantially replace one or more of a user's sensory perceptions of
31 the real world with a virtual experience. One example of this type of system is a head-worn
32 display system, such as the VR system 1000 in Figure 10 that mostly or completely covers a
33 user's field of view. The VR system 1000 may include a front rigid body 1002 and a band
34 1004 shaped to fit around a user's head. The VR system 1000 may also include output audio

1 transducers 1006(A) and 1006(B). Furthermore, while not shown in Figure 10, the front rigid
2 body 1002 may include one or more electronic elements, including one or more electronic
3 displays, one or more IMUs, one or more tracking emitters or detectors, and/or any other
4 suitable device or system for creating an artificial reality experience. Although not shown, the
5 VR system 1000 may include the computer system 130.

6 **[00122]** Artificial reality systems may include a variety of types of visual feedback
7 mechanisms. For example, display devices in the AR system 900 and/or the VR system 1000
8 may include one or more liquid-crystal displays (LCDs), light emitting diode (LED) displays,
9 organic LED (OLED) displays, and/or any other suitable type of display screen. Artificial
10 reality systems may include a single display screen for both eyes or may provide a display
11 screen for each eye, which may allow for additional flexibility for varifocal adjustments or for
12 correcting a user's refractive error. Some artificial reality systems may also include optical
13 subsystems having one or more lenses (e.g., conventional concave or convex lenses, Fresnel
14 lenses, or adjustable liquid lenses) through which a user may view a display screen.

15 **[00123]** In addition to or instead of using display screens, some artificial reality systems
16 include one or more projection systems. For example, display devices in the AR system 900
17 and/or the VR system 1000 may include micro-LED projectors that project light (e.g., using a
18 waveguide) into display devices, such as clear combiner lenses that allow ambient light to pass
19 through. The display devices may refract the projected light toward a user's pupil and may
20 enable a user to simultaneously view both artificial reality content and the real world. Artificial
21 reality systems may also be configured with any other suitable type or form of image projection
22 system.

23 **[00124]** Artificial reality systems may also include various types of computer vision
24 components and subsystems. For example, the AR system 800, the AR system 900, and/or the
25 VR system 1000 may include one or more optical sensors such as two-dimensional (2D) or
26 three-dimensional (3D) cameras, time-of-flight depth sensors, single-beam or sweeping laser
27 rangefinders, 3D LiDAR sensors, and/or any other suitable type or form of optical sensor. An
28 artificial reality system may process data from one or more of these sensors to identify the
29 location of a user, to map the real world, to provide a user with context about real-world
30 surroundings, and/or to perform a variety of other functions.

31 **[00125]** Artificial reality systems may also include one or more input and/or output
32 audio transducers. In the examples shown in Figure 8 and 10, output audio transducers 808(A),
33 808(B), 1006(A), and 1006(B) may include voice coil speakers, ribbon speakers, electrostatic
34 speakers, piezoelectric speakers, bone conduction transducers, cartilage conduction

1 transducers, and/or any other suitable type or form of audio transducer. Similarly, input audio
2 transducers 810 may include condenser microphones, dynamic microphones, ribbon
3 microphones, and/or any other type or form of input transducer. In some embodiments, a single
4 transducer may be used for both audio input and audio output.

5 **[00126]** The artificial reality systems shown in Figures 8-10 may include tactile (i.e.,
6 haptic) feedback systems, which may be incorporated into headwear, gloves, body suits,
7 handheld controllers, environmental devices (e.g., chairs, floormats, etc.), and/or any other type
8 of device or system, such as the wearable devices 102 discussed herein. Additionally, in some
9 embodiments, the haptic feedback systems are incorporated with the artificial reality systems
10 (e.g., the AR system 800 may include the wearable device 102). Haptic feedback systems may
11 provide various types of cutaneous feedback, including vibration, force, traction, texture,
12 and/or temperature. Haptic feedback systems may also provide various types of kinesthetic
13 feedback, such as motion and compliance. Haptic feedback may be implemented using motors,
14 piezoelectric actuators, fluidic systems, and/or a variety of other types of feedback
15 mechanisms. Haptic feedback systems may be implemented independently of other artificial
16 reality devices, within other artificial reality devices, and/or in conjunction with other artificial
17 reality devices.

18 **[00127]** By providing haptic sensations, audible content, and/or visual content, artificial
19 reality systems may create an entire virtual experience or enhance a user's real-world
20 experience in a variety of contexts and environments. For instance, artificial reality systems
21 may assist or extend a user's perception, memory, or cognition within a particular environment.
22 Some systems may enhance a user's interactions with other people in the real world or may
23 enable more immersive interactions with other people in a virtual world. Artificial reality
24 systems may also be used for educational purposes (e.g., for teaching or training in schools,
25 hospitals, government organizations, military organizations, or business enterprises),
26 entertainment purposes (e.g., for playing video games, listening to music, or watching video
27 content), and/or for accessibility purposes (e.g., as hearing aids or vision aids). The
28 embodiments disclosed herein may enable or enhance a user's artificial reality experience in
29 one or more of these contexts and environments and/or in other contexts and environments.

30 **[00128]** Some AR systems map a user's environment using techniques referred to as
31 "simultaneous location and mapping" (SLAM). SLAM mapping and location identifying
32 techniques may involve a variety of hardware and software tools that can create or update a
33 map of an environment while simultaneously keeping track of a device's or a user's location

1 and/or orientation within the mapped environment. SLAM may use many different types of
2 sensors to create a map and determine a device's or a user's position within the map.

3 **[00129]** SLAM techniques may, for example, implement optical sensors to determine a
4 device's or a user's location, position, or orientation. Radios including WiFi, Bluetooth, global
5 positioning system (GPS), cellular or other communication devices may also be used to
6 determine a user's location relative to a radio transceiver or group of transceivers (e.g., a WiFi
7 router or group of GPS satellites). Acoustic sensors such as microphone arrays or 2D or 3D
8 sonar sensors may also be used to determine a user's location within an environment. AR and
9 VR devices (such as the systems 800, 900, and 1000) may incorporate any or all of these types
10 of sensors to perform SLAM operations such as creating and continually updating maps of a
11 device's or a user's current environment. In at least some of the embodiments described herein,
12 SLAM data generated by these sensors is referred to as "environmental data" and may indicate
13 a device's or a user's current environment. This data may be stored in a local or remote data
14 store (e.g., a cloud data store) and may be provided to a user's AR/VR device on demand.

15 **[00130]** When a user is wearing an AR headset or VR headset in a given environment,
16 the user may be interacting with other users or other electronic devices that serve as audio
17 sources. In some cases, it may be desirable to determine where the audio sources are located
18 relative to the user and then present the audio sources to the user as if they were coming from
19 the location of the audio source. The process of determining where the audio sources are
20 located relative to the user may be referred to herein as "localization," and the process of
21 rendering playback of the audio source signal to appear as if it is coming from a specific
22 direction may be referred to herein as "spatialization."

23 **[00131]** Localizing an audio source may be performed in a variety of different ways. In
24 some cases, an AR or VR headset may initiate a DOA analysis to determine the location of a
25 sound source. The DOA analysis may include analyzing the intensity, spectra, and/or arrival
26 time of each sound at the AR/VR device to determine the direction from which the sound
27 originated. In some cases, the DOA analysis may include any suitable algorithm for analyzing
28 the surrounding acoustic environment in which the artificial reality device is located.

29 **[00132]** For example, the DOA analysis may be designed to receive input signals from
30 a microphone and apply digital signal processing algorithms to the input signals to estimate the
31 direction of arrival. These algorithms may include, for example, delay and sum algorithms
32 where the input signal is sampled, and the resulting weighted and delayed versions of the
33 sampled signal are averaged together to determine a direction of arrival. A least mean squared
34 (LMS) algorithm may also be implemented to create an adaptive filter. This adaptive filter

1 may then be used to identify differences in signal intensity, for example, or differences in time
2 of arrival. These differences may then be used to estimate the direction of arrival. In another
3 embodiment, the DOA may be determined by converting the input signals into the frequency
4 domain and selecting specific bins within the time-frequency (TF) domain to process. Each
5 selected TF bin may be processed to determine whether that bin includes a portion of the audio
6 spectrum with a direct-path audio signal. Those bins having a portion of the direct-path signal
7 may then be analyzed to identify the angle at which a microphone array received the direct-
8 path audio signal. The determined angle may then be used to identify the direction of arrival
9 for the received input signal. Other algorithms not listed above may also be used alone or in
10 combination with the above algorithms to determine DOA.

11 **[00133]** In some embodiments, different users may perceive the source of a sound as
12 coming from slightly different locations. This may be the result of each user having a unique
13 head-related transfer function (HRTF), which may be dictated by a user's anatomy including
14 ear canal length and the positioning of the ear drum. The artificial reality device may provide
15 an alignment and orientation guide, which the user may follow to customize the sound signal
16 presented to the user based on their unique HRTF. In some embodiments, an AR or VR device
17 may implement one or more microphones to listen to sounds within the user's environment.
18 The AR or VR device may use a variety of different array transfer functions (ATFs) (e.g., any
19 of the DOA algorithms identified above) to estimate the direction of arrival for the sounds.
20 Once the direction of arrival has been determined, the artificial reality device may play back
21 sounds to the user according to the user's unique HRTF. Accordingly, the DOA estimation
22 generated using an ATF may be used to determine the direction from which the sounds are to
23 be played from. The playback sounds may be further refined based on how that specific user
24 hears sounds according to the HRTF.

25 **[00134]** In addition to or as an alternative to performing a DOA estimation, an artificial
26 reality device may perform localization based on information received from other types of
27 sensors. These sensors may include cameras, infrared radiation (IR) sensors, heat sensors,
28 motion sensors, global positioning system (GPS) receivers, or in some cases, sensor that detect
29 a user's eye movements. For example, an artificial reality device may include an eye tracker
30 or gaze detector that determines where a user is looking. Often, a user's eyes will look at the
31 source of a sound, if only briefly. Such clues provided by the user's eyes may further aid in
32 determining the location of a sound source. Other sensors such as cameras, heat sensors, and
33 IR sensors may also indicate the location of a user, the location of an electronic device, or the
34 location of another sound source. Any or all of the above methods may be used individually

1 or in combination to determine the location of a sound source and may further be used to update
2 the location of a sound source over time.

3 **[00135]** Some embodiments implement the determined DOA to generate a more
4 customized output audio signal for the user. For instance, an acoustic transfer function may
5 characterize or define how a sound is received from a given location. More specifically, an
6 acoustic transfer function may define the relationship between parameters of a sound at its
7 source location and the parameters by which the sound signal is detected (e.g., detected by a
8 microphone array or detected by a user's ear). An artificial reality device may include one or
9 more acoustic sensors that detect sounds within range of the device. A controller of the
10 artificial reality device may estimate a DOA for the detected sounds (using, e.g., any of the
11 methods identified above) and, based on the parameters of the detected sounds, may generate
12 an acoustic transfer function that is specific to the location of the device. This customized
13 acoustic transfer function may thus be used to generate a spatialized output audio signal where
14 the sound is perceived as coming from a specific location.

15 **[00136]** Once the location of the sound source or sources is known, the artificial reality
16 device may re-render (i.e., spatialize) the sound signals to sound as if coming from the direction
17 of that sound source. The artificial reality device may apply filters or other digital signal
18 processing that alter the intensity, spectra, or arrival time of the sound signal. The digital signal
19 processing may be applied in such a way that the sound signal is perceived as originating from
20 the determined location. The artificial reality device may amplify or subdue certain frequencies
21 or change the time that the signal arrives at each ear. In some cases, the artificial reality device
22 may create an acoustic transfer function that is specific to the location of the device and the
23 detected direction of arrival of the sound signal. In some embodiments, the artificial reality
24 device may re-render the source signal in a stereo device or multi-speaker device (e.g., a
25 surround sound device). In such cases, separate and distinct audio signals may be sent to each
26 speaker. Each of these audio signals may be altered according to a user's HRTF and according
27 to measurements of the user's location and the location of the sound source to sound as if they
28 are coming from the determined location of the sound source. Accordingly, in this manner, the
29 artificial reality device (or speakers associated with the device) may re-render an audio signal
30 to sound as if originating from a specific location.

31 **[00137]** Although some of various drawings illustrate a number of logical stages in a
32 particular order, stages which are not order dependent may be reordered and other stages may
33 be combined or broken out. While some reordering or other groupings are specifically
34 mentioned, others will be obvious to those of ordinary skill in the art, so the ordering and

1 groupings presented herein are not an exhaustive list of alternatives. Moreover, it should be
2 recognized that the stages could be implemented in hardware, firmware, software or any
3 combination thereof.

4 **[00138]** The foregoing description, for purpose of explanation, has been described with
5 reference to specific embodiments. However, the illustrative discussions above are not
6 intended to be exhaustive or to limit the scope of the claims to the precise forms disclosed.
7 Many modifications and variations are possible in view of the above teachings. The
8 embodiments were chosen in order to best explain the principles underlying the claims and
9 their practical applications, to thereby enable others skilled in the art to best use the
10 embodiments with various modifications as are suited to the particular uses contemplated.

11

1 What is claimed is:

2 1. A wearable device, comprising:

3 a strap;

4 a base coupled to the strap;

5 a display detachably coupled to the base; and

6 a camera embedded within the display, wherein the display is configured to rotate

7 around an axis normal to the base to adjust an orientation of the camera with respect to the

8 base.

9 2. The wearable device of claim 1, wherein the display includes two or more cameras

10 having distinct lenses.

11 3. The wearable device of claim 2, wherein the lenses of the two or more cameras are

12 selected from the group consisting of: a macro lens, a prime telephoto lens, an optical zoom

13 lens, and a normal lens.

14 4. The wearable device of claim 1, wherein adjusting the orientation of the camera

15 changes a field-of-view of the camera.

16 5. The wearable device of claim 1, wherein the display is a first display, and the

17 wearable device assembly further comprises a second display having one or more second

18 cameras embedded within the second display, distinct from the first display, the second

19 display configured to detachably couple to the base in place of the first display.

20 6. The wearable device of claim 1, wherein the base and the display are both square

21 shaped, the base and the display are both circular in shape, or the base and the display are

22 both rectangular in shape.

23 7. The wearable device of claim 1, wherein the base and the display share a shape that

24 has a plurality of rotational symmetries around a central perpendicular axis to the display.

25 8. The wearable device of claim 1, wherein the base includes one or more pads

26 configured to electromagnetically connect to one or more pads of the display.

27 9. The wearable device of claim 1, wherein the display includes one or more pads

28 configured to electrically connect to one or more pads of the base.

29 10. The wearable device of claim 1, wherein the base includes one or more pads

30 configured to electrically connect to one or more pads of the display.

31 11. The wearable device of claim 10, wherein the one or more pads of the display are

32 configured to magnetically adhere to the one or more pads of the base using magnetic

33 coupling between the pads of the display and the pads of the base.

34 12. The wearable device of claim 10, and any one of:

- 1 a) wherein the one or more pads of the display are configured to mechanically latch to the
2 one or more pads of the base; or
3 b) wherein the display is configured to make an electrical connection between the one or
4 more pads of the display with the one or more pads of the base at any of a predetermined set
5 rotational orientations of the display with respect to the base.

6 13. A method, comprising:

7 at a wearable device having a strap, a base coupled to the strap, and a first display
8 detachably coupled to the base, wherein the first display has a first camera:

9 detaching the first display from the base; and

10 attaching a second display to the base, wherein the second display (i) is distinct
11 from the first display and (ii) has a second camera.

12 14. The method of claim 13, and any one of:

13 a) further comprising:

14 rotating the second display about an axis normal to the base in a first direction to
15 capture, using the second camera, a first field-of-view; and

16 rotating the second display about the axis normal to the base in a second direction,
17 distinct from the first direction, to capture, using the second camera, a second field-of-view
18 that is distinct from the first field-of-view; or

19 b) wherein the second display includes two or more cameras having distinct lenses; in which
20 case optionally wherein the lenses of the two or more cameras are selected from the group
21 consisting of: a macro lens, a prime telephoto lens, an optical zoom lens, and a normal lens;

22 or

23 c) wherein the base includes one or more pads configured to electrically connect to respective
24 pads of the first display or the second display, or the base includes one or more pads
25 configured to electromagnetically connect to respective pads of the first display or the second
26 display; or

27 d) wherein the base includes one or more pads and each of the first and the second displays
28 is configured to make a respective electrical connection between respective pads of the
29 respective display with the one or more pads of the base at any of a set of predetermined
30 rotational orientations of the respective display with respect to the base.

31 15. A system, comprising:

32 a wearable device, including:

33 a strap;

34 a base coupled to the strap;

1 a display detachably coupled to the base; and
2 a camera embedded within the display, wherein the display is configured to rotate
3 around an axis normal to the base to adjust an orientation of the camera with respect to the
4 base; and
5 an artificial reality headset in communication with the wearable device.
6

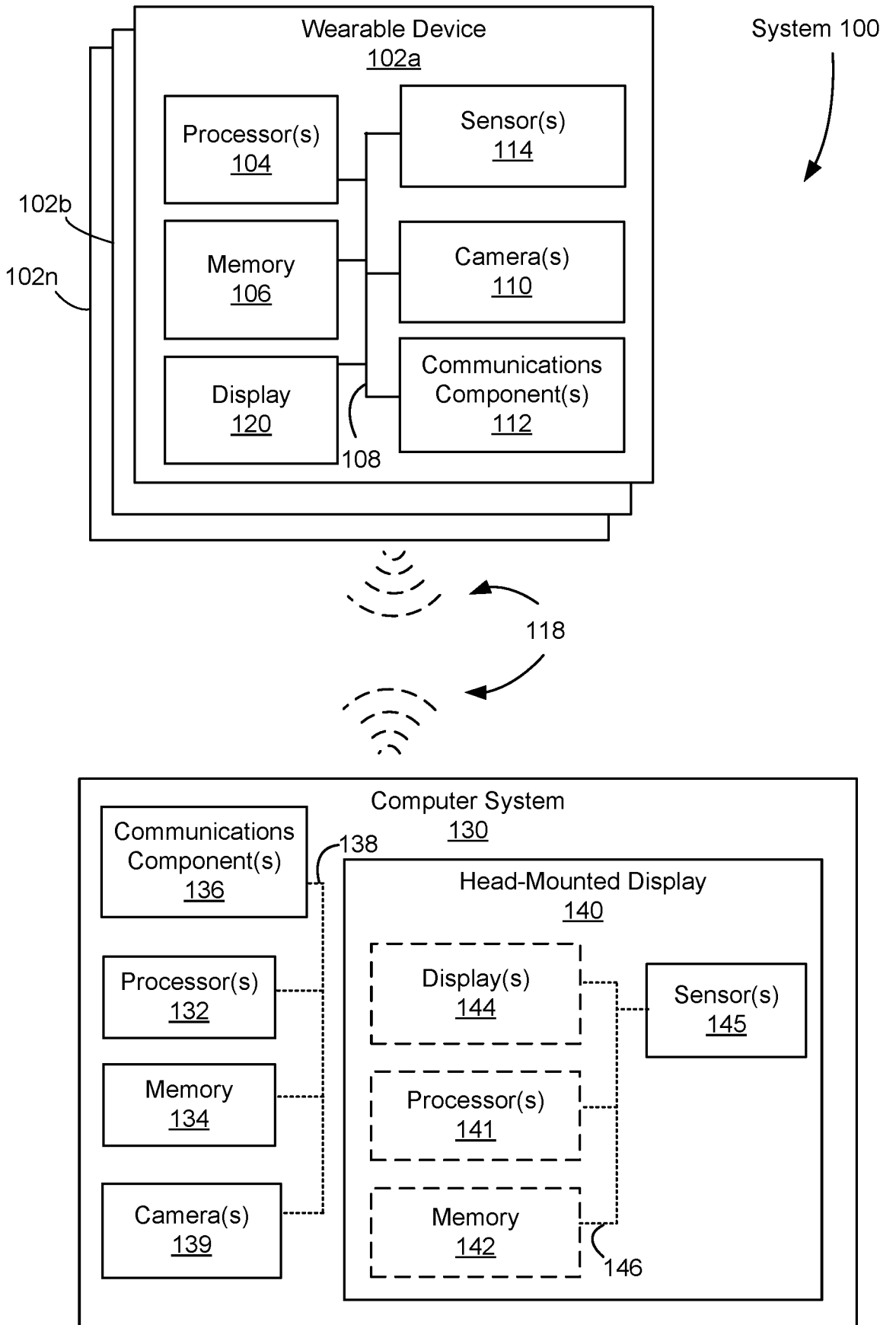

Figure 1

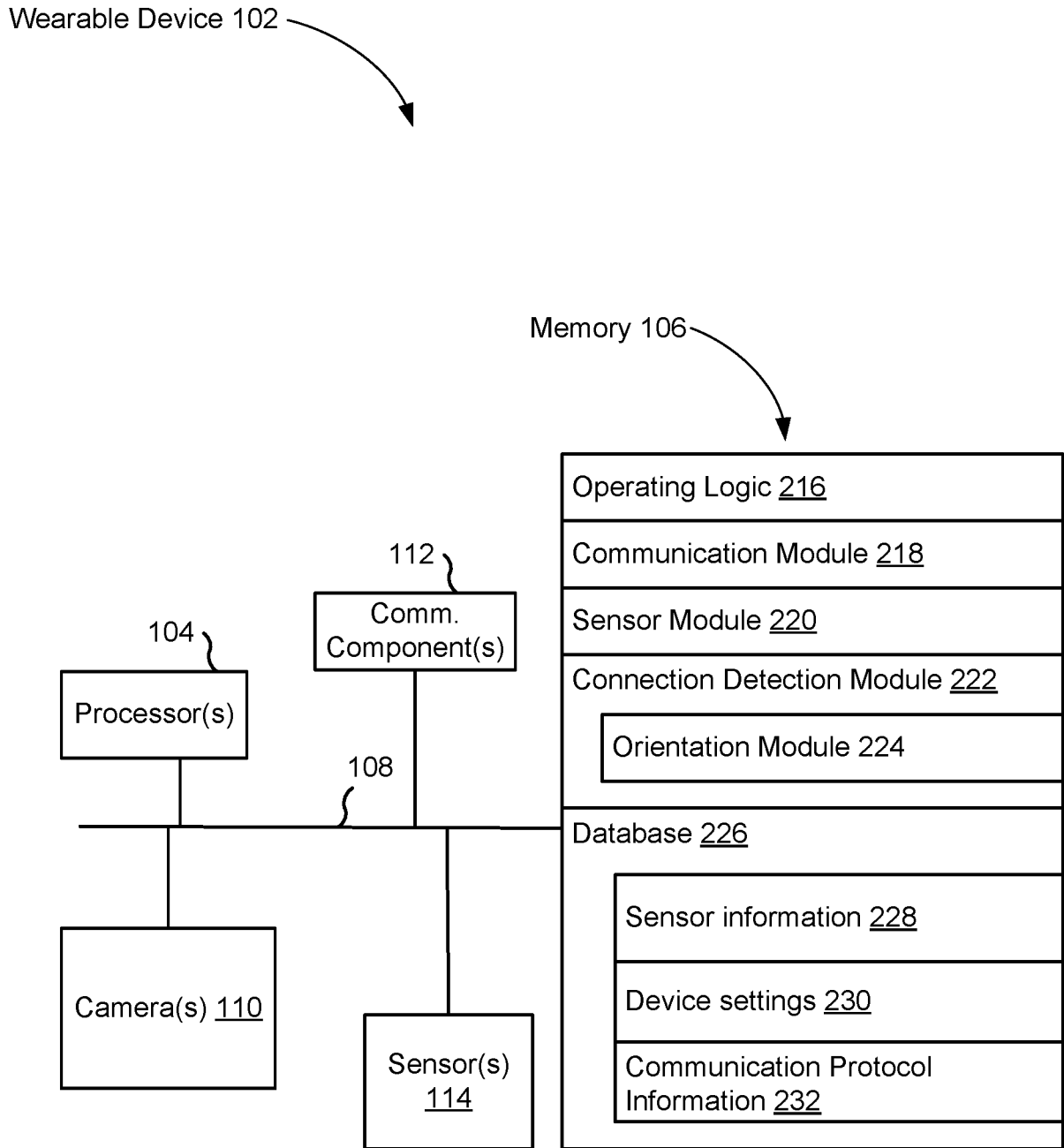
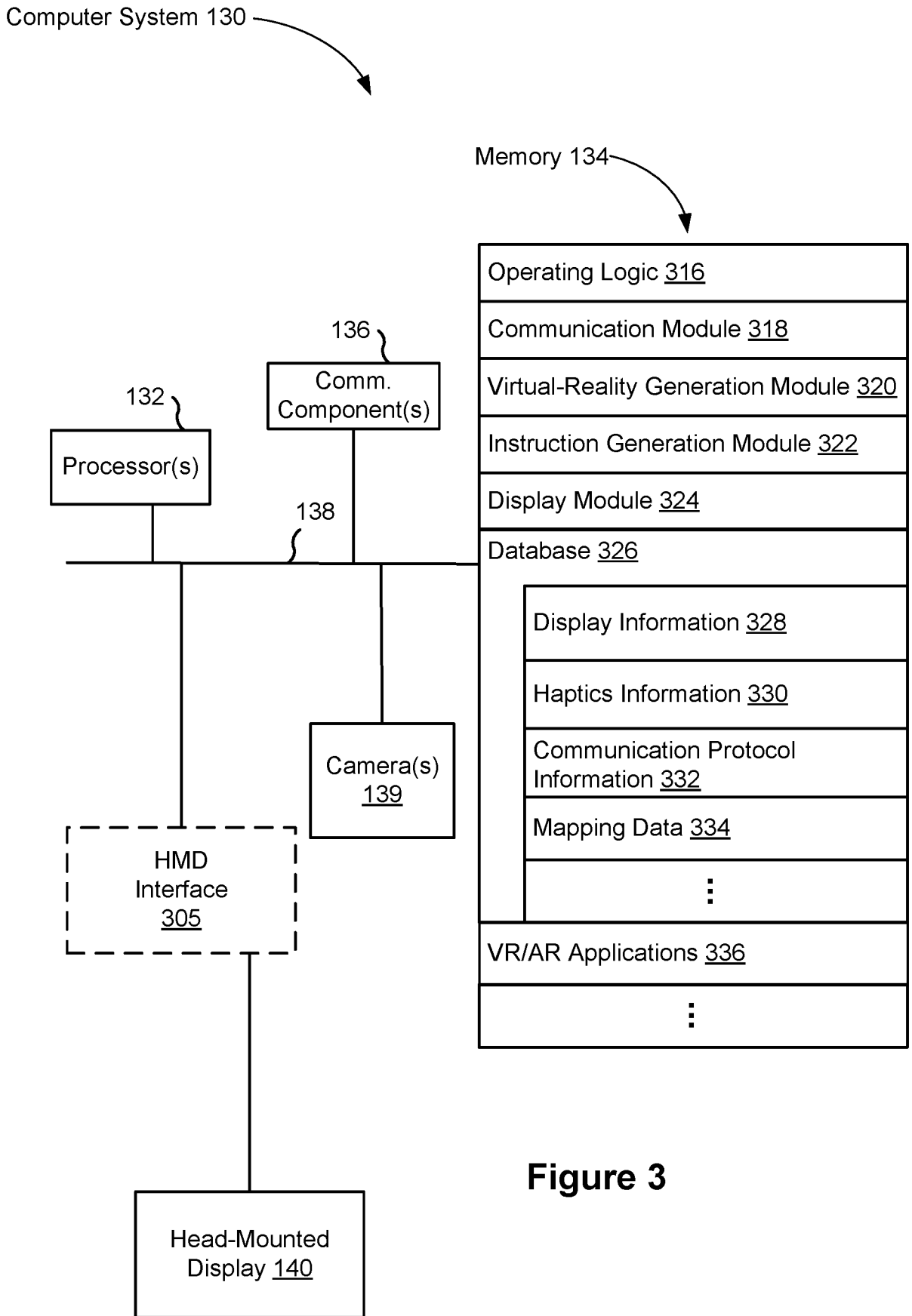

Figure 2



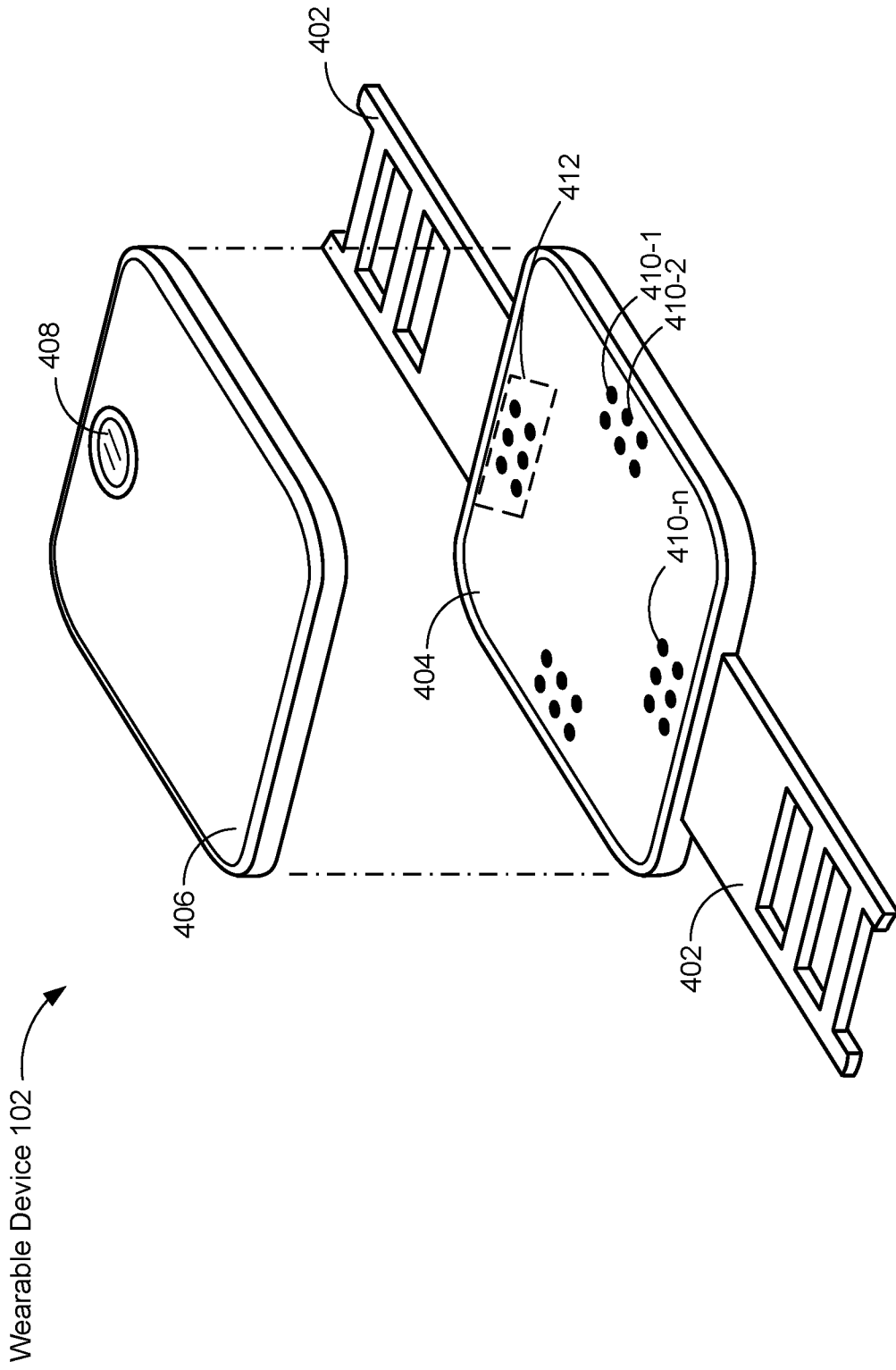

Figure 4

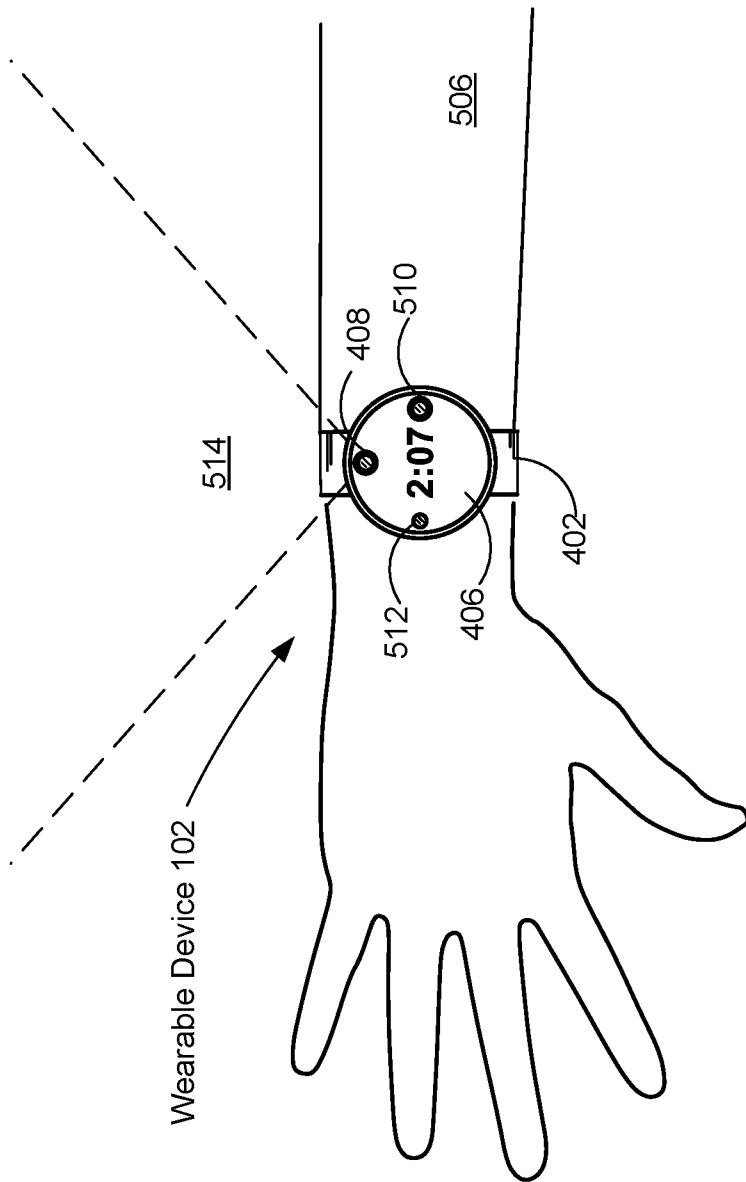

Figure 5

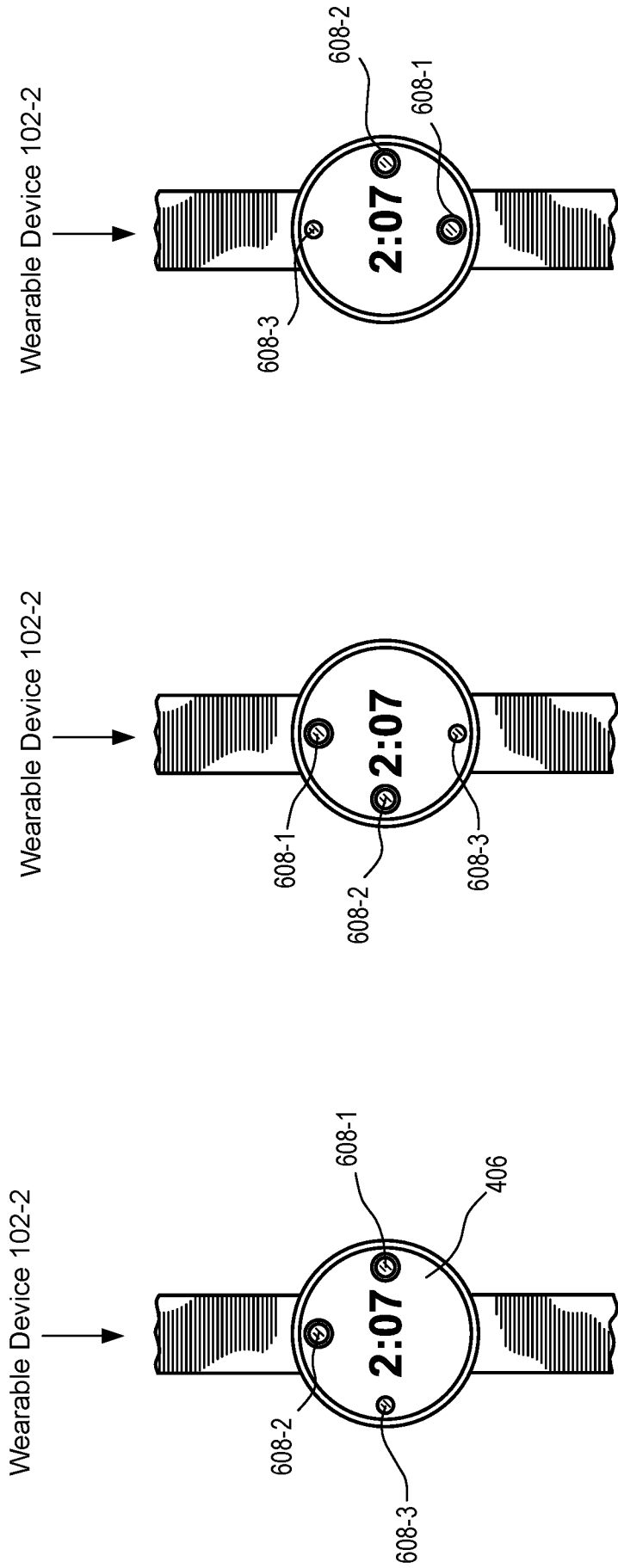
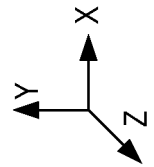

Figure 6C

Figure 6B

Figure 6A



700

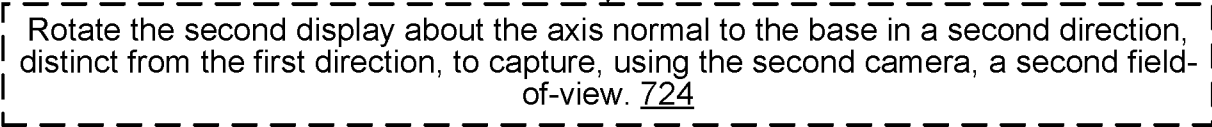
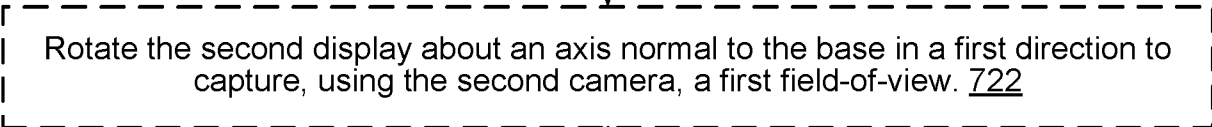
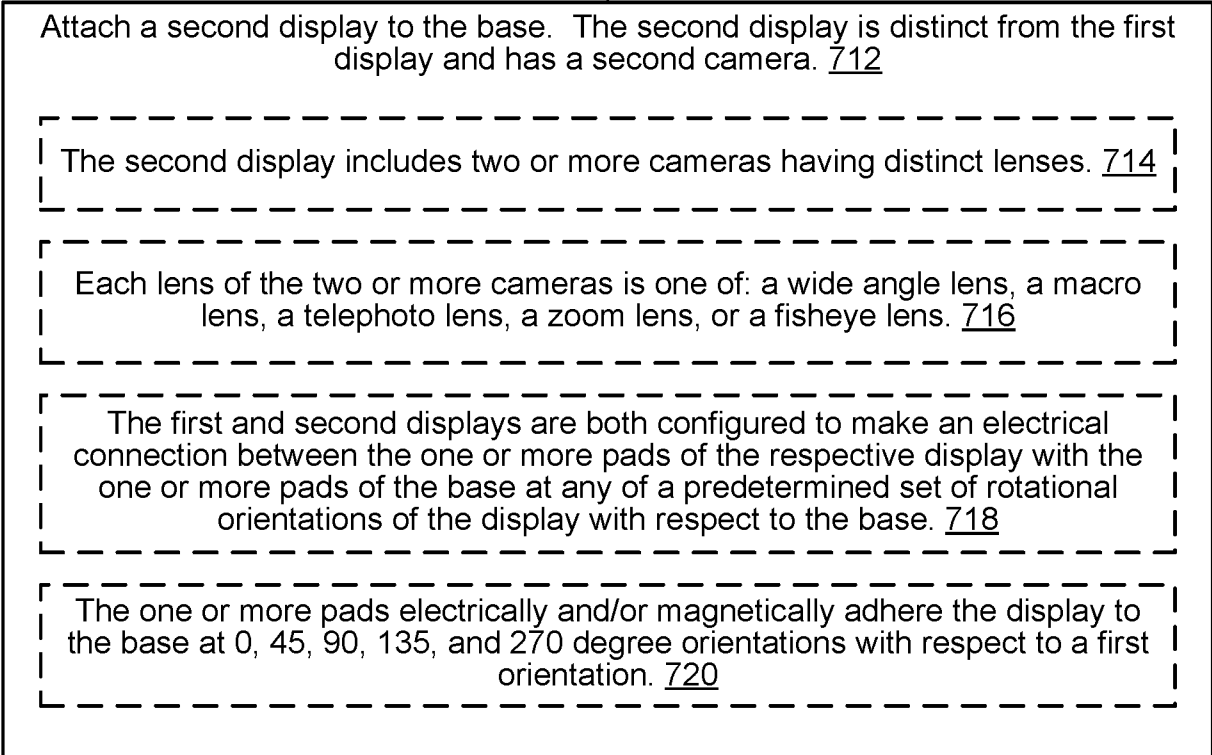
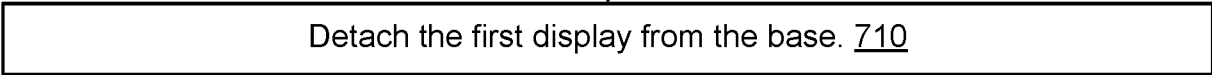
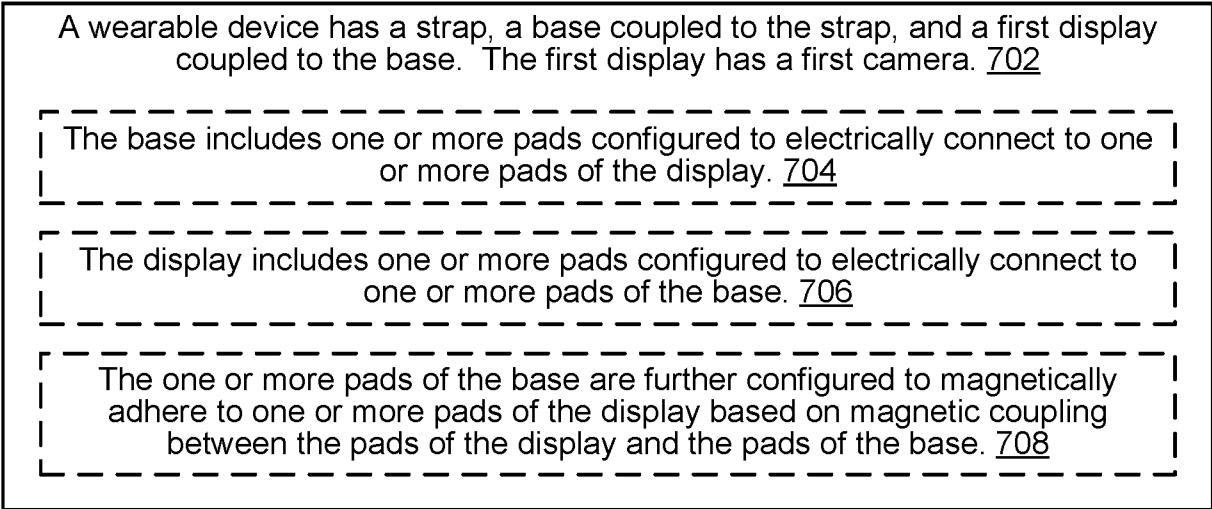

Figure 7

AR System 800 →

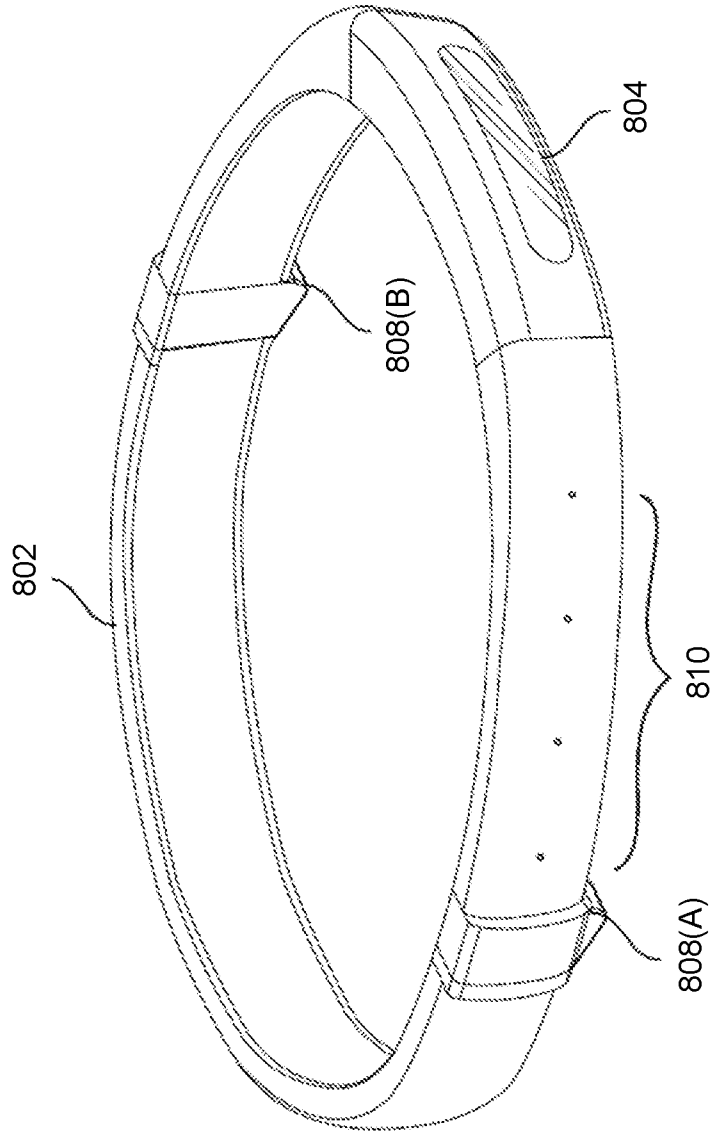

Figure 8

AR System 900

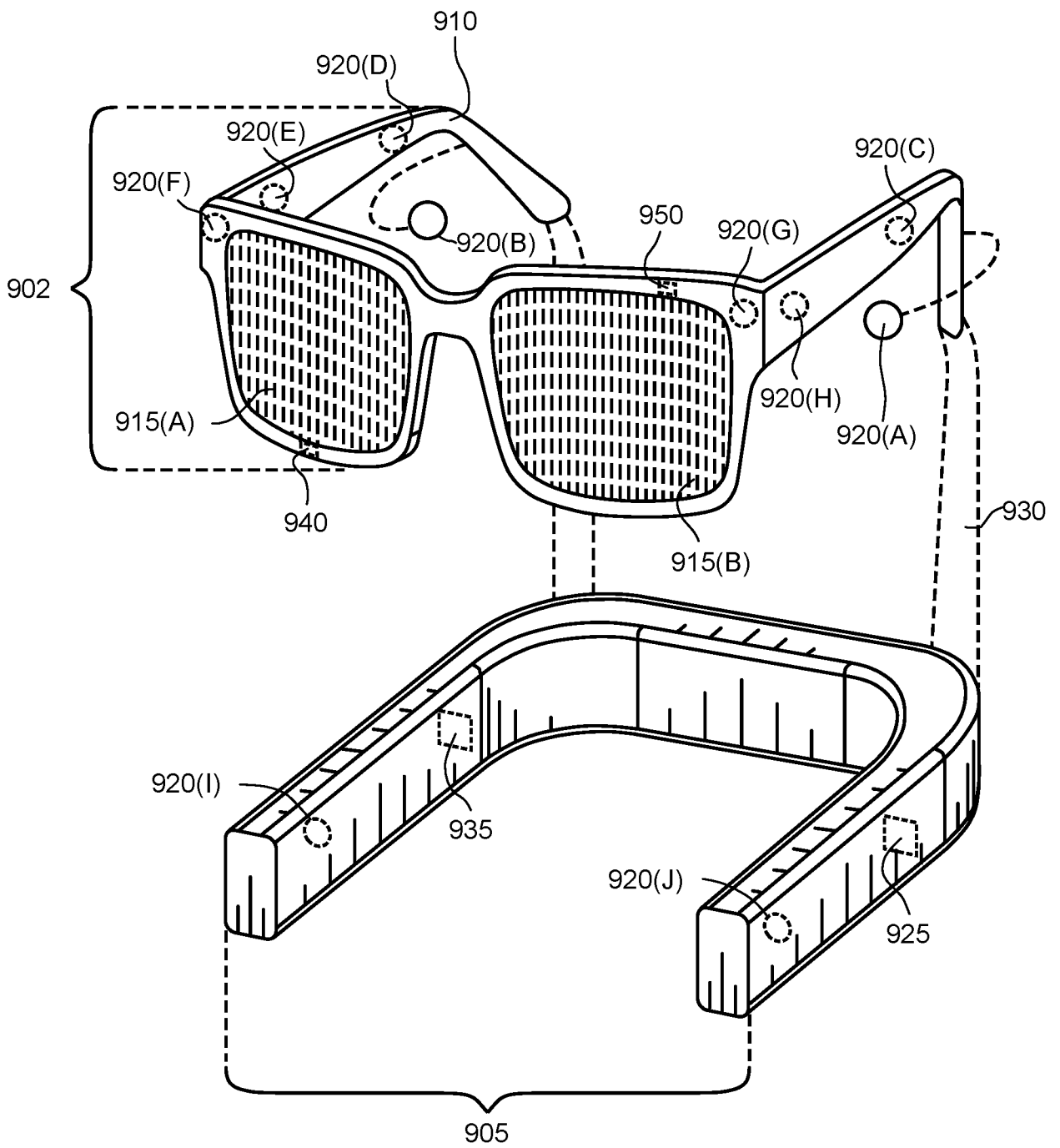

Figure 9

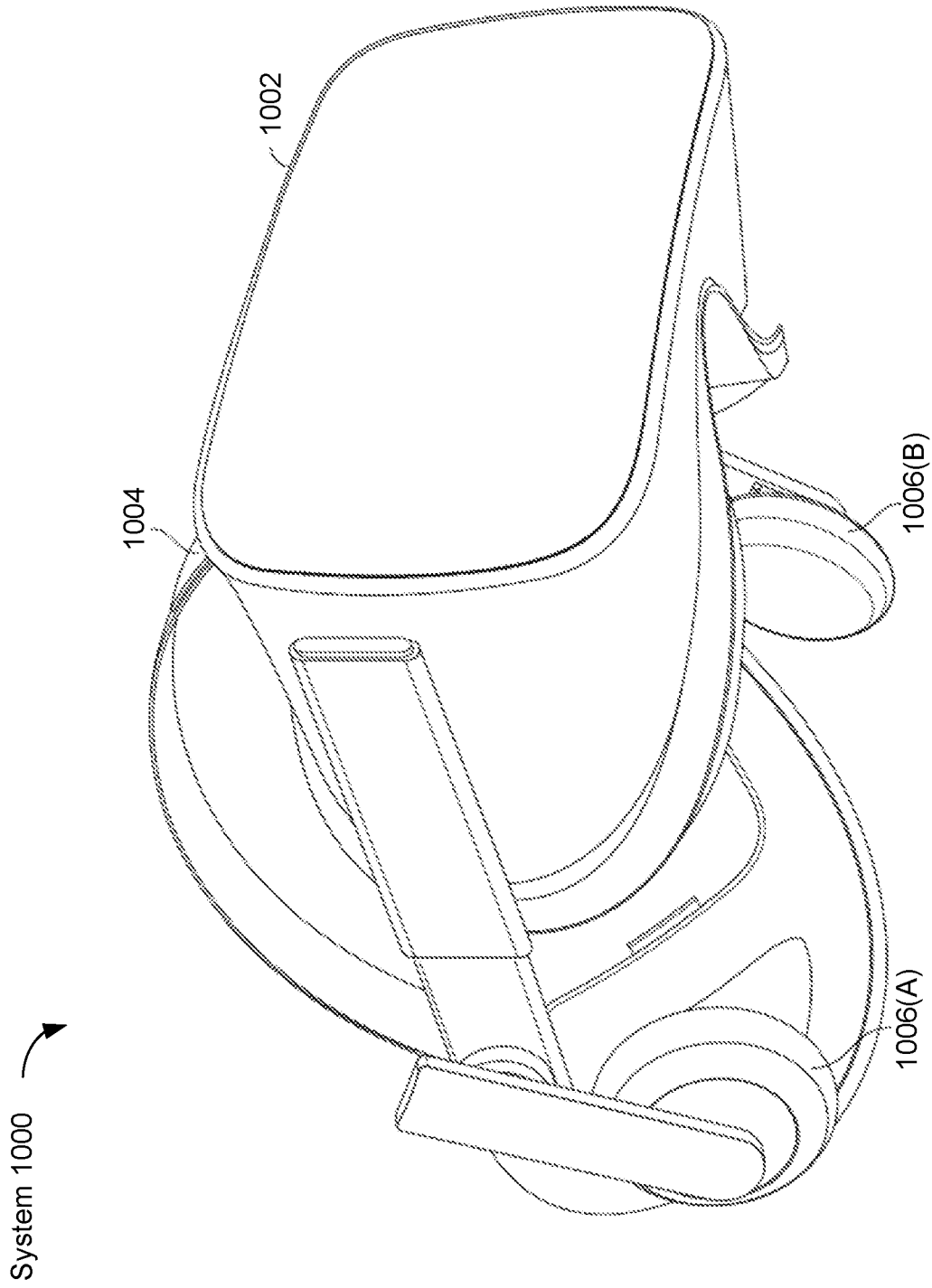

Figure 10

INTERNATIONAL SEARCH REPORT

International application No
PCT/US2021/038929

A. CLASSIFICATION OF SUBJECT MATTER
 INV. G03B15/00 G03B17/00 G03B17/56 G03B29/00
 ADD.
 According to International Patent Classification (IPC) or to both national classification and IPC

B. FIELDS SEARCHED
 Minimum documentation searched (classification system followed by classification symbols)
 G03B

Documentation searched other than minimum documentation to the extent that such documents are included in the fields searched

Electronic data base consulted during the international search (name of data base and, where practicable, search terms used)
 EPO-Internal, WPI Data

C. DOCUMENTS CONSIDERED TO BE RELEVANT

Category*	Citation of document, with indication, where appropriate, of the relevant passages	Relevant to claim No.
X	US 2018/152215 A1 (SIMPSON III GEORGE A [US]) 31 May 2018 (2018-05-31)	1-13
A	paragraph [0027] - paragraph [0062]; figures 1-7C	15
X	US 2017/255019 A1 (LYONS FRANKLIN A [US]) 7 September 2017 (2017-09-07)	1-15
X	paragraph [0076] - paragraph [0089]; figures 1-6	1-15
X	WO 2015/102464 A1 (SAMSUNG ELECTRONICS CO LTD [KR]) 9 July 2015 (2015-07-09)	1-15
A	the whole document	1-15
A	US 2017/249862 A1 (BORDER JOHN N [US]) 31 August 2017 (2017-08-31)	1-15
	paragraph [0104] - paragraph [0108]; figure 16	
	----- -/--	

Further documents are listed in the continuation of Box C.

See patent family annex.

* Special categories of cited documents :

<p>"A" document defining the general state of the art which is not considered to be of particular relevance</p> <p>"E" earlier application or patent but published on or after the international filing date</p> <p>"L" document which may throw doubts on priority claim(s) or which is cited to establish the publication date of another citation or other special reason (as specified)</p> <p>"O" document referring to an oral disclosure, use, exhibition or other means</p> <p>"P" document published prior to the international filing date but later than the priority date claimed</p>	<p>"T" later document published after the international filing date or priority date and not in conflict with the application but cited to understand the principle or theory underlying the invention</p> <p>"X" document of particular relevance; the claimed invention cannot be considered novel or cannot be considered to involve an inventive step when the document is taken alone</p> <p>"Y" document of particular relevance; the claimed invention cannot be considered to involve an inventive step when the document is combined with one or more other such documents, such combination being obvious to a person skilled in the art</p> <p>"&" document member of the same patent family</p>
---	---

Date of the actual completion of the international search 17 September 2021	Date of mailing of the international search report 29/09/2021
--	--

Name and mailing address of the ISA/ European Patent Office, P.B. 5818 Patentlaan 2 NL - 2280 HV Rijswijk Tel. (+31-70) 340-2040, Fax: (+31-70) 340-3016	Authorized officer Tomezzoli, Giancarlo
--	--

INTERNATIONAL SEARCH REPORT

International application No
PCT/US2021/038929

C(Continuation). DOCUMENTS CONSIDERED TO BE RELEVANT		
Category*	Citation of document, with indication, where appropriate, of the relevant passages	Relevant to claim No.
A	GB 2 565 792 A (PAUL STEPHEN TOLLEY [GB]) 27 February 2019 (2019-02-27) page 8, line 25 - page 9, line 30; figures 1-5 -----	1-15

INTERNATIONAL SEARCH REPORT

Information on patent family members

International application No PCT/US2021/038929

Patent document cited in search report	Publication date	Patent family member(s)	Publication date
US 2018152215	A1	31-05-2018	NONE

US 2017255019	A1	07-09-2017	CA 2938895 A1 27-08-2015
			CA 3027407 A1 27-08-2015
			CN 106104361 A 09-11-2016
			EP 3108287 A1 28-12-2016
			JP 2017511041 A 13-04-2017
			US 2015234189 A1 20-08-2015
			US 2015234192 A1 20-08-2015
			US 2015234193 A1 20-08-2015
			US 2015234501 A1 20-08-2015
			US 2015235426 A1 20-08-2015
			US 2016253006 A1 01-09-2016
			US 2016334628 A1 17-11-2016
			US 2017255019 A1 07-09-2017
			US 2019265488 A1 29-08-2019
			WO 2015126987 A1 27-08-2015

WO 2015102464	A1	09-07-2015	NONE

US 2017249862	A1	31-08-2017	US 2017246070 A1 31-08-2017
			US 2017248788 A1 31-08-2017
			US 2017248792 A1 31-08-2017
			US 2017249860 A1 31-08-2017
			US 2017249861 A1 31-08-2017
			US 2017249862 A1 31-08-2017
			US 2021161752 A1 03-06-2021
			WO 2017151494 A1 08-09-2017

GB 2565792	A	27-02-2019	NONE
